

Annual Report 2018

**Reports of the
Federal Highway Research Institute**

A 40



bast

Federal Highway Research Institute

The Federal Highway Research Institute (Bundesanstalt für Straßenwesen, BAST) was founded in 1951. BAST began its work with research in the field of highway construction. In 1965 BAST was commissioned, beyond the scope of highway construction tasks, to work towards enhancing highway capacity and safety. In 1970 the Federal Parliament voted to establish a central agency for road traffic accident research which was set up at BAST.

Today BAST is a practice-oriented, technical and academic research institute of the Federal Government with a focus on the road sector. It covers diverse research subjects resulting from the relationship between road, people, and the environment. Its function consists of improving the safety, environmental compatibility, economic viability, and efficiency of roads.

BAST provides scientifically based decision support to the Federal Ministry of Transport and Digital Infrastructure (Bundesministerium für Verkehr und digitale Infrastruktur, BMVI) in technical and transport policy issues. BAST is among the leading institutes in a network of centres of research excellence in the roads sector, and substantially involved in developing regulations and standards at the international level. Consultancy and expert opinions, reviewing and certifying are also among BAST's functions. Moreover, BAST is an assessment centre for driving licensing.

Its headquarters have been in Bergisch Gladbach since 1983 on premises covering about 20 hectares, including ten experimental halls and large-scale test facilities, some of them unique in the world.

Annual Report 2018

**Reports of the
Federal Highway Research Institute**

A 40

bast

Publisher:

Bundesanstalt für Straßenwesen
Brüderstraße 53
D-51427 Bergisch Gladbach
Phone +49 2204 43-0
www.bast.de
info@bast.de

Edited by:

Press and Public Relations Office

Translated by:

Hatice Demircan

Editorial deadline: December 2018

Picture credits:

Federal Highway Research Institute, Guido Rosemann (BASt), page 10,11 Busakorn Pongparnit/Moment/Getty Images, 22,23 querbeet/iStock/Getty Images Plus/Getty Images, 32,33 Westend61/Getty Images, 46,47 ollo/E+/Getty Images, 60,61 STOCK4B-RF/Getty Images and as indicated

Printed and published by:

Fachverlag NW in der
Carl Ed. Schünemann KG
Zweite Schlachtpforte 7
D-28195 Bremen
Telefon 0421 36903-53
Telefax 0421 36903-48
www.nw-verlag.de

ISSN 0943-9285

ISBN 978-3-95606-464-7

Bergisch Gladbach, June 2019

Preface

Dealing with changes is our everyday business. We have committed ourselves to improving and increasing the efficiency in constructing and maintaining road infrastructure, as well as to improving its reliability. We intend to improve the performance of the transport system road at the same time as improving road safety and environmental compatibility in road construction and road traffic. We want to make the transport system more resilient and foster technological progress in the roads sector. This means that progress has been our mission since BAST's founding decree in 1951. Since then, we have focused on the changing and new needs of road users and taken visions and mega trends into consideration.

The Zukunftsinstitut futurology centre says on www.zukunftsinstitut.de: "Mega trends do not need to be 'forecast'. They are already there and mark changes that have been and will be shaping us for a long time. ... Mega trends are changing the world – albeit slowly but fundamentally and over the long term".

Mega trends as defined by the Zukunftsinstitut harbour opportunities but also risks. It is important to seize the opportunities and minimise the risks. Mega trends are changing our society and naturally also have an impact on a research institute

such as the Federal Highway Research Institute (Bundesanstalt für Straßenwesen, BAST). In the era of connectivity and knowledge culture in an increasingly networked world, having a structure is more important than ever to counteract permanent sensory overload. The development of various in-house planning instruments addresses this issue.

With this annual report, we are looking back at the past research year. Part of our work is visible and in the public eye, such as the field trial with longer goods vehicles, our unique duraBAST research premises at the autobahn intersection Köln-Ost and our innovative MESAS measuring vehicle to record road conditions in moving traffic. A large part of our work is less visible but no less important, such as continuously updating technical rules and regulations, reviewing and approving products and procedures and compiling projections and statistics.

As of now, we will publish our reports on an annual basis, because we want to inform and update you faster about our work and our projects. You are holding an attractive cross-section of our multifaceted research work of the past year in your hands. Allow us to provide inspiration and give a 'face' to our research on the following pages



Stefan Strick, President of BAST

Content

Highlights 2018	6
Vehicle Engineering	10
Turn assist systems for truck drivers	12
SENIORS – EU research project	14
Personal Light Electric Vehicles	16
Highly automated driving on autobahns	18
Updating exhaust emissions tests	20
Green NCAP	21
Road Safety	22
Cycling and road safety	24
Senior citizens in road traffic	26
Medicinal cannabis	28
Accidents involving heavy goods transport vehicles	29
20 years of quality assurance in driving licence services	30
Traffic Engineering	32
Digital autobahn: harmonisation – test – introduction	34
Dynamic traffic management	36
Innovative tool to support accident commissions	37
New guidelines for more road safety	38
Multiple safety barrier requirements	40
Immission control and nature conservation across all modes of transport	41
BIM in the federal trunk roads sector	42
Fingerprint of road markings	45

Highway Construction	47
Innovation in concrete pavements – surface performance	48
Quality-assured processes in strategic maintenance planning	52
New evenness indicator for contractual acceptance tests.....	54
Chemical impact of calcium hydroxide on bitumen	55
Load tests and economic assessment.....	56
Thermography in asphalt road construction.....	58
Bridges and Structural Technology.....	60
Cyber-Safe.....	62
Shear strength of prestressed concrete bridges	64
Expansion joints – developments in Germany and Europe.....	67
BASt Facts and Figures 2018.....	68
Awards/PhDs/Teaching Assignments	70
BASt Organisational Structure	72

Highlights 2018

BAST's Scientific Advisory Board enhanced and expanded

Prof. Barbara Lenz and former State Secretary Rainer Bomba have been supporting BAST's Scientific Advisory Board since spring 2018. Prof. Lenz heads the Institute for Transport Research at the German Aerospace Centre (DLR) in Berlin. She is a transport geographer; her research focuses especially on issues of viable mobility for the future, such as mobility and transport behaviour and transport demand. Rainer Bomba is an engineer and economist. He was State Secretary at the Federal Transport Ministry from November 2009 to March 2018.



Technical Advisory Councils “Road Safety” and “Road Infrastructure”



Already in 2017, BAST reorganised the existing structure of its advisory committees. The former Scientific Advisory Board was replaced by an overarching Advisory Board and two Technical Advisory Councils. This new structure is intended to create more space for technical expertise about BAST's focal topics. The new Advisory Board, as an overarching body, will focus on strategic issues spanning all of BAST by their nature. The Advisory Board consists of people with leadership experience in scientific-institutional or ministerial fields. Two Technical Advisory Councils on “Road Safety” and “Road Infrastructure” also advise BAST in strategic matters, but with a more technical focus on the respective topic in question.

Meeting of the “Road Infrastructure” Technical Advisory Council in November 2018

Changing functions within BAST



Since May 2018, Dr. Ingo Koßmann has headed the “Behaviour and Safety” department. He is a sociologist and joined BAST in 1994 in the “Attitude and Behaviour of Road Users” section. Dr. Koßmann held leadership functions within the “Behaviour and Safety” and “Traffic Engineering” departments, most recently as the head of the “Research

Coordination, Library and Documentation Centre” section at the General Administration department.

Markus Lerner became Dr. Koßmann’s successor and is now heading the “Research Coordination, Library and Documentation Centre”. He is a geographer and has been with BAST since 2000.



The interim head of the “Connected Mobility” section in the “Automotive Engineering” department, Dr. Lutz Ritterhaus, took over this position permanently in May 2018. Dr. Ritterhaus is a physicist and engineer and has been with BAST since 2004.

Open House event of the Federal Government

Federal Minister Andreas Scheuer and Formula 1 champion Nico Rosberg were two of the many guests visiting BAST’s booth at the Federal Transport Ministry during the Open House of the Federal Government on 25 and 26 August 2018.

Positioned beside other exhibitors, BAST presented itself with its new bicycle simulator. It will be used for research in the future on issues related to safe cycling, such as: when and why do cyclists use their smart phone? What factors influence a cyclist’s perception of danger?



duraBAST: BAST's Demonstration, Investigation and Reference Area

Studies have been taken up at the testing grounds at the autobahn intersection Köln-Ost: innovative road structures are being tested that were developed as part of the "Road in the 21st Century" research programme, as well as programmes by industrial partners. Additionally, vacant spaces are being made available to the private sector to test, study and demonstrate new technologies. Numerous guests have visited the premises since it was inaugurated in October 2017. Initial projects have already been completed.



TRA 2018 and DSVK

The TRA 2018 (Transport Research Arena) took place in Vienna in April 2018. Experts from around the globe discussed the latest developments in the fields of traffic, transport and mobility. BAST was represented with a number of expert presentations and in poster sessions and at the joint booth of BAST and the Federal Ministry of Transport and Digital Infrastructure (BMVI) in the German trade fair pavilion.

New MESAS measuring vehicle

Since March 2018, BAST has been using its innovative MESAS measuring vehicle (multi-functional recording system to evaluate road condition and road structure). It enables measurements to record the structural condition of roads in moving traffic at speeds of up to 80 km/h. The measuring vehicle is based on a Traffic Speed Deflectometer (TSD) to measure load capacity, recording by means of laser technology short-term minor deformations of the road



surface under a truck axle. The TSD measuring system – developed and constructed in Denmark – currently exists in thirteen vehicles around the world.

BAST was also represented with seven speakers and one moderator at the German Road and Transport Congress (DSVK) at the trade fair in Erfurt in September 2018. At the joint BAST and BMVI booth, information was provided on the topics of reforming the federal trunk roads administration, the BMVI's Expert Network, innovations, asset management and digitisation.

The large innovative MESAS truck was one highlight that was presented to a wider public for the first time.

Visitors at BAST

BAST is a federal practice-oriented, technical-scientific research institute in the roads sector and works as a lead within the international network of top research institutes.

Guests from Germany and abroad visit BAST regularly. Most of the visitors comprise visiting groups of experts from the fields of academia, industry and administration who are interested either in an overview of the different test facilities or in a scientific exchange on specific research topics. Visiting scholars from abroad usually come to BAST with a special research mission and leave with new insights on both sides. In 2018, many politicians also made use of the possibility to visit BAST for an individual exchange.

Intensive conversations with BAST's management and its specialists inspired a lively exchange of ideas. Visits to the test set-ups, some of which are unique, enabled guests to witness BAST's practical research activities.



August 2018: Transport Minister of North Rhine Westphalia Hendrik Wüst (right) and the Parliamentary State Secretary at the Federal Transport Ministry Steffen Bilger (second from the right)



July 2018: MP Kirsten Lühmann (centre) with the working group on transport and digital infrastructure of the German Social Democratic Party



April 2018: MP Stephan Kühn (third from the right)



May 2018: Director General Jens Holmboe from the Danish Road Directorate with the heads of his organisation's departments

Vehicle Engineering

Turn assist systems for truck drivers

SENIORS – EU research project

Personal Light Electric Vehicles

Highly automated driving on autobahns

Updating exhaust emissions tests

Green NCAP





Turn assist systems for truck drivers

Dr. Jost Gail, physicist, head of the "Active Vehicle Safety and Driver Assistance Systems" section

Dr. Patrick Seiniger, mechanical engineer, deputy head of the "Active Vehicle Safety and Driver Assistance" section

Alexander Frey, psychologist, "Automated Driving" section

Benjamin Schreck, traffic engineer, "Accident Analysis, Safety Concepts, Road Safety Economics" section

Accidents involving trucks and cyclists often have serious consequences. Vulnerable road users are run over without truck drivers noticing them beforehand. Truck drivers' inadequate fields of vision to their front and to the bottom right was already analysed in detail as the subject matter of DEKRA's "The danger pedestrians and cyclists are exposed to at intersections when trucks turn right" study [1].

Turn assist systems, providing truck drivers with targeted information if they run the risk of overlooking a cyclist, are one solution to this type of road accidents. The facts related to turn assist systems for commercial vehicles were already discussed with associations involved – including ADFC (German Cyclists Association), VDA (German Association of the Automotive Industry), DVR (German Road Safety Council), GDV (German Insurance Association) – at round-table meetings convened by the BMVI (Federal Ministry of Transport and Digital Infrastructure) in 2012 and 2014. As a follow-up, BASt was commissioned to design a test

procedure for such assistance systems on the basis of state-of-the-art technology.

Concept for a turn assist system

Providing information to the truck driver by means of a technical system is the core of this concept.

This information must be provided at an early enough stage that truck drivers have sufficient time to bring their vehicle to a halt. Consequently, this means these systems must make the information available before the drivers start the turning process: i.e., they must already receive a corresponding signal when overtaking cyclists. As experience with detection algorithms is hardly available, automatic braking is not considered an option at this time.

Man-Machine Interaction

The information signal of the turn assist system must be clearly visible to truck drivers – before they initiate the actual turning process.

However, the information should not disturb or distract the driver from the driving task at hand. This thus rules out a high-intensity warning that would serve as initial information about cyclists. These requirements can be fulfilled with a clearly visible information signal in the right outer part of the human field of vision (peripheral): the alert appears in the direction of the potential hazard, i.e., to the driver's right. In addition, this makes use of the driver's natural viewing direction when preparing to turn right. Using side mirrors in time before turning can also be supported with this assistance system.

Developing requirements for test procedures and legal regulation

Characteristic parameters and the circumstances of accidents involving cyclists and trucks turning were identified on the basis of analyses of accident situations. The set of parameters compiled in this way helped define test cases for turning-right situations and corresponding passing criteria the test. [2].

Verification tests have been conducted. Based on the findings, a German proposal for a regulation document was drawn up early in 2017.

Regulations in the field of automotive engineering are mainly negotiated under the umbrella of the United Nations, more precisely at its Economic Commission for Europe – UNECE – and published as UN regulations (formerly: ECE regulations). Almost

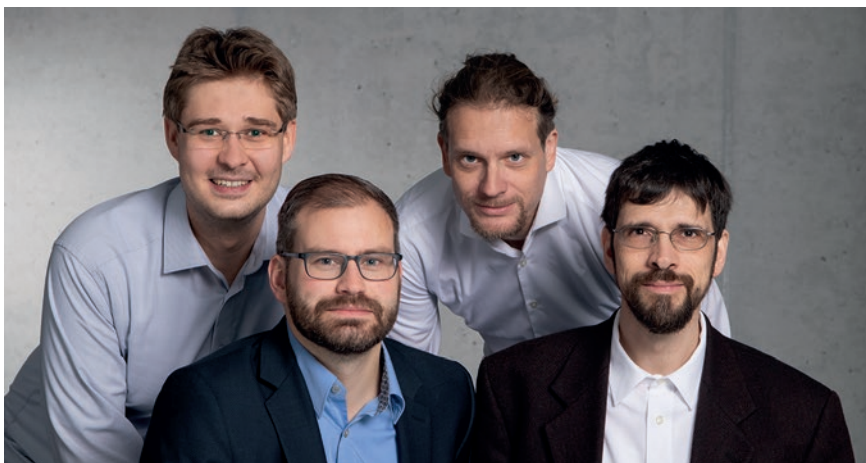

Left to right: Alexander Frey, Benjamin Schreck, Dr. Patrick Seiniger and Dr. Jost Gail



every individual regulation used for the European approval of vehicle types now refers to UN regulations. In this respect, a UN regulation for a turn assist system is a first step towards the mandatory introduction of turn assist systems.

Implementation

The proposal for a turn assist system developed by BASt and introduced by Germany was welcomed at the relevant UN body – the Working Group on General Safety – and referred to an informal international panel of experts for further fine-tuning. This took place in 2017 and 2018; the Working Group on General Safety adopted the draft regulation without any dissenting votes. The approval of the highest body – the “World Forum for Harmonization of Vehicle Regulations” – is expected for spring 2019. This means that a valid specification document will be available in autumn 2019, including deadlines for the decision-making process.

The EU Commission is currently planning to take turn assist sys-

tems into account in amending its regulation on the general safety of motor vehicles: “General Safety Regulation” 661/2009 and to make them mandatory for heavy vehicles presumably as of 2022 (new types) and 2024 (new registrations). Reference will be made in this case to the corresponding specifications document.

Retrofitting

The process of introducing international regulations for new vehicle types and new vehicles thus requires significant lead times. However, in order to address the accident situation quickly, Federal Transport Minister Andreas Scheuer launched the “Turn Assist System Campaign” in early July 2018. As part of this campaign, the BMVI (Federal Ministry of Transport and Digital Infrastructure) has committed itself to retrofitting all heavy-duty vehicles in its fleet with turn assist systems and to procuring only new vehicles that have such systems installed. A large number of official security partners have joined the campaign with similar voluntary commitments. BASt has also devel-

oped requirements for retrofitting systems that can be used as a basis to support the retrofitting of heavy-duty vehicles and buses. ■

References

- [1] NIEWÖHNER, W., BERG, F. A.: *The danger to pedestrians and cyclists from trucks turning right* Gefährdung von Fußgängern und Radfahrern durch rechts abbiegende Lkw, Berichte der Bundesanstalt für Straßenwesen, Heft F 54, 2004
- [2] SCHRECK, B., SEINIGER, P.: *Turn assist systems for trucks – test procedure basics* Abbiege-Assistenzsystem für Lkw – Grundlagen eines Testverfahrens, Berichte der Bundesanstalt für Straßenwesen, Heft F 104, 2015

SENIORS – EU research project

Dr. Andre Eggert, mechanical engineer, Marcus Wisch, mechatronics engineer and Oliver Zander, engineer for safety technology, deputy head of the “Passive Vehicle Safety, Biomechanics” section

The SENIORS (Safety ENhancing Innovations for Older Road userS) project funded by the European Commission aimed to significantly improve the safety of senior citizens in road traffic. The project addressed possibilities in the field of improved passive vehicle safety and focused on older people as vehicle occupants, pedestrians and cyclists in collisions with passenger cars. From June 2015 to May 2018, eight European partners developed new test tools as well as test and assessment procedures under the lead of BAST as consortium partner.

Vehicle occupants

Collision data shows that older vehicle occupants are at a higher risk of a chest injury than younger vehicle occupants, even in lower and moderate-speed crashes at 30 to 40 kilometres per hour. To integrate this aspect, a variety of approaches was pursued as part of the SENIORS project.

Human body model

A new human body model was developed to correspond to the rib cage of older people in terms of material property and geometry. Overlaying images of the rib cage of an older person with that of a younger one shows significant geometrical differences which, in combination with changed properties – for instance of bones and cartilage, can result in different injury patterns under strain and in car crashes.

Thorax injury criteria

The team of researchers also developed improved injury criteria for the frontal impact dummy THOR. They followed a new, simulation-based method based on comparative computer simulations of a human body model and a THOR dummy model. By simulating numerous strain conditions using different impact strain and occupant restraint systems, it was possible to juxtapose the sim-

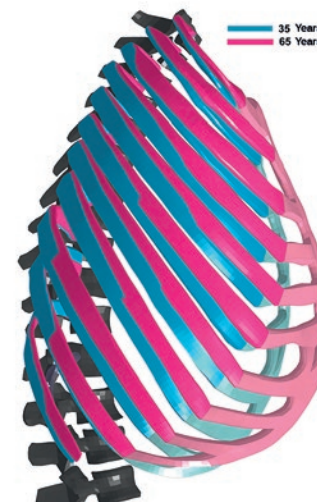

Rib cage geometry of a 35-year-old person and a 65-year old

ulated measurement results of the dummies to the injury probabilities of human ribs. The injury criteria for the THOR dummy were optimised in this way in the area relevant for older road users.

Test and assessment methods

The new criteria enable important strain differentiations, especially on the rib cage area, and thereby supporting the targeted development of improved airbag and seat belt systems. It is intended to further develop these injury criteria in research activities with the automotive industry and consumer protection organisations such as Euro NCAP (European New Car Assessment Programme) and incorporate them into future test and assessment procedures.

The researchers also recommended the introduction of a frontal impact test with reduced impact speed: 35 kilometres per hour compared to standard tests at about 56 to 64



Left to right: Oliver Zander, Dr. Andre Eggert and Marcus Wisch

kilometres per hour. Sled tests have shown that these proposals can illustrate the benefits of modern occupant restraint systems – such as adaptive systems and four-point belt systems – and thus enable improved protection, especially for older vehicle occupants.

Pedestrians and cyclists

Studies of road traffic accidents involving pedestrians and cyclists (external road users) and passenger cars from a number of European countries – including Germany and Sweden – show that the strong relevance of injuries to the head and lower extremities has remained unchanged, while at the same time the severity of thorax injuries have increased. For people over 65 years of age, the injury relevance of these body areas increases again in comparison with the age group of 24-64-year olds. The SENIORS project therefore focused on assessing the protection potential of vehicle fronts with regard to mitigating injuries to the head, chest and lower extremities.

Head

Test requirements for the protection of external road users have so far focused mainly on pedestrians, as they are still the largest group of vulnerable road users. Though cyclists also sometimes benefit from these test procedures, in crashes they are subject to different general conditions, such as different speeds and higher head impact areas and angles. These boundary conditions were taken up in the SENIORS project, and a combined test procedure for both pedestrians and cyclists was implemented.



THOR sled test with four-point belt system

Thorax

At present, neither consumer protection requirements nor regulatory requirements call for a test procedure to test the protection of the rib cages of pedestrians and cyclists. Current injury patterns were used as an opportunity to develop a prototype for the Thorax Injury Prediction Tool (TIPT) as part of a test procedure for vehicle components. For this purpose, the rib cage of the EuroSID2 occupant dummy still used in side impact legislation today was isolated and connected to the existing test rig environment. Earlier finite element simulations using a THUMS model (Total HUMAN Model for Safety) crashing against several generic vehicle fronts provided the necessary test parameters for speed, impact angle and impactor approach angle. Through vehicle categorisation, it was then possible to define the test parameters per vehicle to be tested. The impact areas on the test vehicle in turn result from anthropometry and the geometries of the EuroSID2 dummy and the human body model.

Lower extremities

Starting with the limitations of the FlexPLI (Flexible Pedestrian Legform Impactor) leg impactor currently used in various test specifications, the SENIORS project investigated the extent to which the simulation of an upper body mass of pedestrians (UBM) contributes to improved impact kinematics, and a more realistic depiction of the strain on the human body. The findings gained from comparative FE simulations comparing the THUMS human body model and the FlexPLI leg impactor with and without upper body mass resulted in a prototype. This prototype is a much more realistic representation of both the real time delay of the upper body rotation and the measured strain on the leg during a pedestrian impact against a vehicle front compared to the previously deployed FlexPLI. The FlexPLI-UBM makes it possible, for the first time, to illustrate in one comprehensive test the strain on the thigh in addition to the strain on the knee and lower leg. The impact of pedestrians crashing against SUVs is also shown with adequate accuracy up to

a certain height of the engine hood's front edge. Finally, the rotation of the impactor that occurs in crashes with heavily bevelled vehicle fronts can be significantly reduced.

The changed test parameters using the FlexPLI-UBM are based in turn on anthropometry and the geometries of FlexPLI and the human body model. The strain on the thigh has been identified for assessment purposes using a transfer function from injury risk functions. For the knee and lower leg, it was possible to transfer the existing criteria for FlexPLI to the impactor with UBM.

Assessment procedure

The new and changed impactor tests have led to a proposal for a similarly modified assessment procedure for consumer protection. This takes into account the changes in human injury patterns on the one hand, and leaves room on the other for other modifications that may still be necessary. These are particularly necessary because the thorax impactor is currently still at an early stage in its development due to its limitations in an angular impact.

Outlook

The findings of the SENIORS project concerning injuries to the head and lower extremities are intended to be incorporated into Euro NCAP as part of consumer protection. A follow-up project has also been planned to further revise the thorax injury prediction tool and related test and assessment protocols. ■



www.seniors-project.eu

Personal Light Electric Vehicles

Maxim Bierbach, mechanical engineer, and Oliver Bartels, physicist, "Active Vehicle Safety and Driver Assistance Systems" section
Alexander Frey, physicist, "Automated Driving" section
Bernhard Kollmus, traffic engineer, "Highway Design, Traffic Flow, Traffic Control" section

Since the introduction of the European Framework Regulation on two- and three-wheel vehicles and quadricycles in 2016 (Regulation (EU) 168/2013), it has become possible to nationally regulate the approval of small stand-up and

self-balancing electric vehicles, such as electrically powered scooters or Segways. An assessment of their road safety was required, in order to be able to decide on these vehicles' type approval.

As part of its research project "Study on Personal Light Electric Vehicles" [1], BASt developed proposals for classifying Personal Light Electric Vehicles as well as for the technical requirements these vehicles must meet. On this basis, it will be possible to decide about approving such vehicles for use on public roads. The vehicles were analysed with regard to the following aspects: active and passive safety, user behaviour and risk assessment and the traffic areas to be used by them.

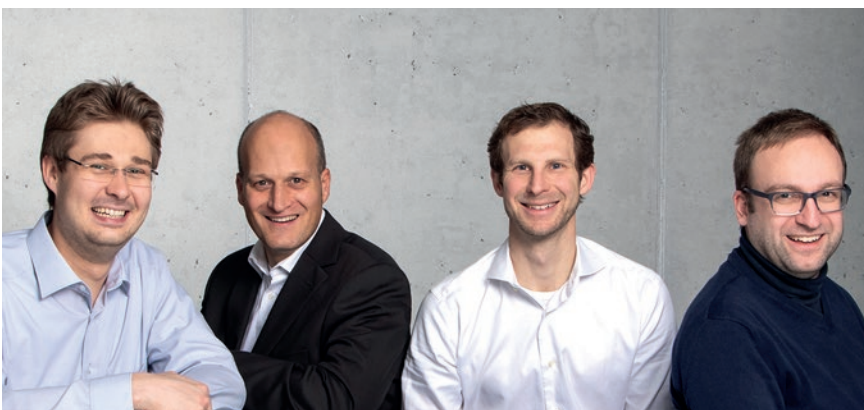

Left to right: Alexander Frey, Oliver Bartels, Maxim Bierbach and Bernhard Kollmus

Active safety

In terms of active safety, requirements were developed using dynamic driving tests and technical

tests to ensure an adequate level of vehicle safety. Recommendations concerning the passive safety of Personal Light Electric Vehicles are intended to ensure a level of safety similar to that of today's vehicles. The subjective assessment of driving behaviour showed that fundamentally Personal Light Electric Vehicles can be safely controlled as long as certain vehicle-dependent dynamic driving limits are complied with.

Looking at aspects of user behaviour, protective gear and relative strength vis-a-vis other road users were evaluated. There are recommendations for the use of corresponding traffic areas depending on the proposed vehicle category. It is planned to assess the potential for conflict with other road users and safety issues while driving on public roads, especially as part of the scientific support provided by BAST for the actual use of such vehicles in road traffic.

Test specifications concerning driving dynamics of Personal Light Electric Vehicles

Minimum requirements for the driving dynamics are recommended for the vehicles – in particular self-balancing ones – in order to ensure their safe use in road traffic, minimising the risks posed by this new technology to their drivers and other road users. Such specifications for the driving behaviour of Personal Light Electric Vehicles did not exist prior to this. Test specifications (minimum requirements) for the driving dynamics of Personal Light Electric Vehicles will be developed in a follow-up study, including a test procedure for possible later use by technical inspection services.



Examples of test vehicles

Insurance plates for Personal Light Electric Vehicles

Personal Light Electric Vehicles classified as motor vehicles are subject to mandatory insurance and thus necessitate an insurance plate that can be applied on the vehicle. Smaller license plates have been designed for this special area for application; they were tested in a study for recognition distance and colour differentiation.

National ordinance on Personal Light Electric Vehicles: eKFV

The Federal Ministry of Transport and Digital Infrastructure (BMVI) has initiated a draft ordinance on the participation of Personal Light Electric Vehicles with handlebars and handrail in road traffic, based on the findings of a BAST study and another draft ordinance for the exemption of Personal Light Electric Vehicles without such a bar. These ordinances are intended to create the legal framework for the use of specific Personal Light

Electric Vehicles on public roads. BAST was commissioned to provide scientific support for the introduction of these vehicles. ■

References

- [1] BIERBACH, M., ADOLPH, T., FREY, A., KOLLMUS, B., BARTELS, O., HOFFMANN, H., HALBACH, A.-L.: *Study on Personal Light Electric Vehicles* Untersuchung zu Elektrokleinstfahrzeugen, Berichte der Bundesanstalt für Straßenwesen, Heft F 125, 2018

Highly automated driving on autobahns

Alexander Frey, psychologist, "Automated Driving" section and Peter Lubrich, civil engineer, "Connected Mobility" section



The Ko-HAF (cooperative, highly automated driving) research project aims for safe highly automated driving at speeds of up to 130 kilometres per hour on autobahns. The vehicles take over continuous longitudinal and transverse control – meaning speed control and steering angle control. Drivers do not have to continuously monitor vehicle behaviour and the surrounding traffic environment during this time, but may instead engage in other activities. However, they must be able to take over control and the steering of the vehicle again within a certain time for preparation.

The consolidation of various pieces of vehicle-specific sensor information is necessary but not sufficient for the technical implementation of a highly automated driving function. These sensors – for instance ultra sound, cameras, radar and lidar – enable anticipating traffic situations only to a limited extent. However, the vehicle must receive information about critical events far ahead on the planned route in a timely manner, such as about a vehicle stranded after an accident, an obstacle, road works or a narrow lane ahead. Only in this way can drivers be alerted with a sufficient time buffer to take over manual control of the vehicle. Such cooperative anticipation on the part of highly automated vehicles is enabled in Ko-HAF by means of a Safety Server.

Cooperative, highly automated driving

Other vehicles that have already passed through a specific route section will make pertinent information about the surroundings available. This information is sent to the Safety Server via mobile communication, stored in compressed form and embedded into a digital road map. This enables every highly automated vehicle to access the information on current road and traffic conditions stored there.

The road map is thus an essential element in the cooperative exchange of information. It is a high-precision, layered reference map in accordance with the BMVI's (Federal Transport Ministry) [1] strategy; it is an integrative part of a "smart road".

Ko-HAF has a total budget of 36.3 million euros. It was funded by the Federal Ministry for Economic Affairs and Energy with 16.9 million euros as part of its "New Vehicle and System Technologies" programme.

Besides BAST, a total of 15 other project partners from the private sector, academia and the public sector collaborated closely from June 2015 to November 2018.

Data quality

In addition to technically building up the Safety Server, the challenge lies in furnishing data and information to be exchanged at a high quality to make highly automated driving safe and reliable. As an initial step, a basic understanding of the related quality requirements needs to be created. For this purpose, BAST has developed a quality model as an approach to uniformly describe and assess the data quality in Ko-HAF. The quality model consists of definitions and concepts for the following three levels:

- quality features
- quality requirements
- quality methods

The up-to-date-ness of data was, for instance, referenced as a quality



High-precision, layered digital reference map (image: 3D Mapping Solutions GmbH)

parameter at various interfaces of the Safety Server. Initial findings indicate that the quality model is a good starting point for a uniform approach to the quality of the data ecosystems for highly automated driving. However, additional validations and definitions need to be provided by the players involved.

Data privacy

Data privacy, especially in terms of personally identifiable data, is another important aspect in the context of exchanging data between automated vehicles and the Safety Server. Regulatory frameworks, especially the General Data Protection Regulation (GDPR), are a significant driver of this topic. BAST has hosted a number of workshops together with Ko-HAF project partners to raise awareness and derive solutions that are compatible with data privacy.

Man-Machine Interaction

The human driver's taking (back) vehicle control is of particular significance in highly automated driving. In two elaborately designed empirical studies, BAST evaluated how the driver's condition evolves during automated driving. The driver's condition – such as drowsiness or alertness – is highly safety-relevant at the point that he or she manually takes over vehicle control. For a scientific study, the drowsiness behaviour of test drivers in an automated drive which required continuous monitoring was compared to the drowsiness behaviour during a highly automated drive while at the same time carrying out motivating activities. The brain waves of close to 50 test drivers were monitored to measure drowsiness using an EEG (electroencephalography) in BAST's test vehicle. The duration of automation



EEG monitoring in BAST's research vehicle

on a monotonous test track was more than 60 minutes. Taking into account individual differences in the drivers' drowsiness behaviour, on average a maximum increase in drowsiness was seen after about 20 minutes of driving when the test person had to monitor the driving task continuously. This increase in drowsiness was not detected, however, when the test drivers were engaged in motivating activities during the highly automated drive. Using this approach, it was possible to maintain the driver's condition – as relates to drowsiness – at the preferred alertness level for taking over vehicle control.

Conclusion

The Ko-HAF research project was able to provide important findings to increase the safety of highly automated driving functions. Fundamental research issues were answered here for the first time – and already at a high level of detail – by applying the analytical methods described earlier. This positive response was also shared at the project's concluding presentation in September 2018. At this event, BAST presented the research vehicles deployed and the compiled findings to an interested audience. ■

References

- [1] Federal Ministry for Transport and Digital Infrastructure: *Progress report on the strategy on automated and connected driving*
Bericht zum Stand der Umsetzung der Strategie automatisiertes und vernetztes Fahren, Berlin, 2017

Updating exhaust emissions tests



Sigrid Limbeck, traffic engineer, "Motor Vehicle Emissions" section

The exhaust emissions test for motor vehicles was first introduced in Germany more than 30 years ago and then continuously adapted in its set-up. Today, the exhaust emissions test (AU) is based on the legal provisions of EU Directive 2014/45/EU, transposed into German law by means of the German Road Vehicles Registration and Licensing Regulations (Straßenverkehrszulassungsordnung, StVZO). The test is part of a vehicle's general inspection (HU) and is carried out by licenced inspection centres and workshops.

The environmental impact of vehicle emissions is constantly changing. Further developments in the field of exhaust technology, both for engines and exhaust after treatments, and measuring technology enable the deployment of new measuring methods and devices. Not only the measuring technology but also the transmission of data collected with measurements inside the vehicle offer a possibility to adapt the exhaust emissions test to state-of-the-art technology and, when necessary, even conduct only vehicle-specific tests in the event of anomalies. Current BAST projects are focusing on further developing the measurement of particle numbers for a future emissions test and developing methods to measure emissions in moving traffic.

Measuring particle numbers is a well-established measuring method which is used for the type approval of all vehicles; it provides an indicative evaluation of the emitted particles. During this test, part of the exhaust gases – during a test drive

on a dynamometer or on the road – are sucked into a measuring unit in a heavily diluted form to count the particles with a particle meter. Particles ranging in size between 23 and 100 nanometres are recorded.

It is now intended to transfer this procedure to exhaust emissions testing to ensure that the particle number does not rise significantly throughout a vehicle's lifecycle. Together with inspection centres, BAST is developing a new test cycle for the exhaust emissions test as well as a threshold value proposal. Manufacturers will be supported in developing measuring devices required for this exhaust emissions test by Germany's National Metrology Institute (PTB) and BAST.

Measuring emissions in the vehicle - transmitting data from the vehicle

In the future, it may then be possible to measure all exhaust emissions in the vehicle itself. To this end, sensor technology will be required in the vehicles to measure, for instance, nitrous oxide and particles directly in the driving vehicle, and to then be read via an interface or transmitted to an external entity. This scenario applies to vehicles that are still in the development stage. In one project, BAST is working together with an external research institute on these future-oriented visions for exhaust emissions tests. The possibilities for change are far-reaching and must go hand in hand with both the long-established system of periodic monitoring and the development of new vehicles. ■



Image: Dominique Bruneton/PhotoAlto Agency RF Collections/Getty Images

Green NCAP



Uwe Ellmers, physicist, head of the "Motor Vehicle Emissions" section

The consumer organisation Euro NCAP (European New Car Assessment Programme) has expanded its range of activities to include environmentally relevant aspects of vehicles. As part of a pilot phase, a technical working group set up for this purpose has developed test and assessment procedures for a comparative assessment of the environmental compatibility of passenger vehicles in terms of energy consumption and emissions properties.

Quite deliberately, the test procedures thus developed go significantly further than test procedures for type approvals. Vehicles with various drivetrain systems are tested under conditions that are strongly oriented towards real driving conditions. Existing procedures such as the WLTC (Worldwide harmonized Light Vehicles Test Cycle) were adapted and expanded to include additional components, for instance an autobahn cycle that covers higher speeds and loads. In addition, the general conditions for real driving such as mass, electrical loads and rolling resistance are adjusted to natural conditions to finally assess and evaluate more realistic conditions of use.

Comparable results

The measurements are carried out exclusively in laboratories accredited for this purpose to achieve the best possible comparability of the results. The laboratories underwent simultaneous round robin tests to prove their suitability. At the moment, eight approved European laboratories are participating in the programme.



Image: Green NCAP

The driving and measurement cycles developed by Green NCAP are used to perform measurements on different types of passenger cars both in the laboratory and on the road. The evaluation is based on two pillars: emissions and fuel consumption, or rather efficiency in the case of electrically powered vehicles.

The findings of the pilot phase completed in the meantime show there are significant differences among vehicles. Beside the fact that electric vehicles receive very good ratings – in their case, however, only the vehicle's own energy consumption is evaluated, not the primary generation of the energy –, it has become clear that there has been progress with EURO 6d TEMP vehicles with regard to very low emissions, including under off-cycle conditions.

Conversely, smaller vehicles with small engines may sometimes have problems in the demanding tests, because their engines must operate

at high load levels, and therefore emissions and consumption can increase significantly. Larger vehicles with more powerful engine do not reach their limits as easily but they need to compensate for their greater weight.

Green NCAP aims to give a correspondingly good rating to vehicles that master the optimum balance of performance, emissions and consumption/efficiency. ■



www.greenncap.com



Road Safety

Cycling and road safety

Senior citizens in road traffic

Medicinal cannabis

Accidents involving heavy goods transport vehicles

20 years of quality assurance in driving licence services



Cycling and road safety

Maxim Bierbach, mechanical engineer, "Active Vehicle Safety and Driver Assistance Systems" section
Benjamin Schreck, traffic engineer, "Accident Analysis, Safety Concepts, Road Safety Economics" section
Oliver Zander, safety engineer, deputy head of the "Passive Vehicle Safety, Biomechanics" section

Cycling is currently in fashion in terms of mobility behaviour. It is a rising trend across Germany, most prominently in big cities [1]. A systematic promotion of cycling needs to be seen in the context of climate change mitigation, noise abatement, and air quality control. This is particularly true for urbanised spaces with their increasing difficulties complying with emissions standards. The potential that promoting cycling has for mitigating climate change and specifically for the increasing use of electric bicycles and their environmental impact was quantified in detail.

and related increase in the mobility of senior citizens must also be considered in a proactive manner. Other topics include bicycle highways that create long-distance connections, further developments in vehicle engineering and an increasing proliferation of safety equipment.

Accident situation

Since 2000, accident figures have remained relatively constant, but to some extent slightly increased in the long-term development of the number of cycling accidents and the number of severely or slightly injured

ally, accidents involving cyclists and goods transport vehicles play only a subordinate role, but they very often cause the most serious and fatal injuries. The figures for Pedelec accidents and injured Pedelec cyclists is rising steadily. Much of the increase is due to the soaring rise in Pedelecs 25 sales and their increased use. Here too, senior citizens are disproportionately affected.

Route selection

A pilot study was devoted to route selection and infrastructure use. In a survey, cyclists indicated their preference for cycle paths separated from motor vehicle road traffic. However, observing driving behaviour, roads were most frequently used, and in some cases the illegal use of sidewalks was observed. This can be partially explained by gaps in the cycling infrastructure and incomplete cycle path networks. Overall, the length of the route is the most important factor when choosing a particular route. However, one in five routes chosen also included detours because alternative routes were considered safer. The study's findings are an important basis for communication measures.

Infrastructure

An attractive and safe network of cycle paths is essential for promoting cycling in cities. BAST together with a large number of practitioners has conducted extensive research to support the revision of relevant planning guidelines for traffic engineering, construction and traffic control measures and their effective-

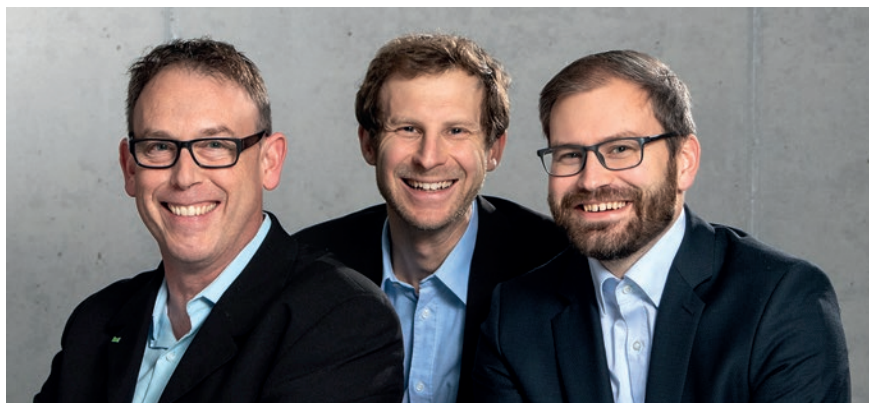

Left to right: Oliver Zander, Maxim Bierbach and Benjamin Schreck

Measures – such as redesigning existing bicycle traffic infrastructure so that it complies with regulations and campaigns to promote cycling – have had positive effects in some cases. The expected increase in the modal share of cycling and a socially and politically desired increase in the attractiveness and promotion of cycling necessitate more research so as not to further disconnect the developments in road safety for cyclists from the positive development in road safety in general. The demographic development

cyclists involved in accidents. One positive trend to be highlighted is the significant long-term decline in the number of cyclists killed in accidents, which has stagnated at around 380 since 2010. The proportion of senior citizens among all cyclists killed is particularly striking. In addition to the characteristic accident constellation involving a cyclist and another vehicle or pedestrian, single-cycle accidents also account for a particular proportion of accidents. One in four cyclists dies in an accident without any other party involved. Proportion-

ness. In addition to routing types – such as cycle lanes and cycle paths – a new instrument has been established with the nation-wide promotion of bicycle highways: bicycle highways are direct connections in the network of cycle paths with an anticipated particularly high demand in traffic, mainly for every-day bicycle traffic – especially for people cycling to work and commuters. These highways are usually separated from areas for other transport modes and must comply with minimum requirements concerning their layout, cross-section and design of intersections. BAST is currently further developing safety-relevant elements besides practice-oriented methods to determine their potential.

Safety equipment and protective gear

In addition to developing “turn assist systems for truck drivers” (see page 12), BAST has also collaborated on the revision of test procedures at the consumer organisation Euro NCAP’s (European New Car Assessment Programme). Since 2018, two different scenarios of emergency braking systems for passenger cars have been examined that are intended to prevent or mitigate collisions with cyclists.

BAST also studied possibilities to improve vehicle-related measures that protect cyclists in the event of a collision. In crash tests as part of the component testing procedure it is possible to map the majority of cyclists’ severe head injuries caused by the impact with a vehicle’s front by means of a rearward extension of the head impact area to at least the front edge of the vehicle’s roof and additional test parameters. Personal protective gear – such as bicycle helmets – has become well-established.



Left: Cyclist dummy for testing emergency braking systems



Right: Dummy head impact on windscreen

lished. BAST’s studies have shown that the strain on the cyclist’s head is reduced by more than 60 per cent by wearing a helmet.

Cross-sectional safety research programme

Shifting the choice of transport mode towards non-motorised transport can make a significant contribution to a more environmentally-friendly type of mobility. Further research activities are required covering the human aspect, safety equipment, and infrastructure to be able to analyse and evaluate various questions and potential problems. The main objective is to create more scientific fundamentals and measures to promote cyclists’ safe behaviour in road traffic. Against this backdrop, particular attention needs to be paid to the development of road safety, as cyclists account for the most severe and serious injuries in the total number of traffic accidents. BAST’s interdisciplinary safety research programme “Road safety on roads within urban areas” addresses this focal issue with more than 25 national and international projects and its own separate cross-departmental working group. Due to the adaptability of the research programme, practice-relevant and new ques-

tions can be included and analysed more quickly to further increase road safety in bicycle traffic. ■

References

[1] BMVI 2018:14 ff., *Mobility in Germany, summary report, traffic volumes – structure – trends* *Mobilität in Deutschland, Kurzreport, Verkehrsaufkommen – Struktur – Trends*, www.mobilitaet-in-deutschland.de



Section of a bicycle highway with a bicycle traffic space of four metres in width

Senior citizens in road traffic

Dr. Hardy Holte, psychologist, "Traffic Psychology, Traffic Education" section

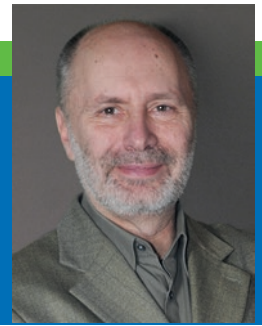

Due to the demographic shift, BAST has focused in recent years on issues relating to the safety and accident risk of older road users. Last year, two extensive research projects with this focus were concluded: one an overview of the current status of road safety research concerning senior citizens that discusses possible measures to improve their road safety [1] and an empirical study to identify especially at-risk older drivers of passenger cars [2].

Study on the demographic shift

Data on the involvement of senior citizens in accidents and key findings on their mobility needs, age-related driving-relevant functional changes and compensation mechanisms of older drivers were collected and evaluated. The data revealed that the total group of

drivers aged 65 and above is significantly less frequently involved in accidents resulting in personal injury than younger age groups are. The proportion of people aged 65 and older in the total group of people injured in traffic accidents is 12.6 per cent and – measured against their share in the population of 21.1 per cent – is clearly under-represented. Nonetheless, an increase in the number of older people involved in accidents is to be expected as a result of demographic developments. In addition, the greater vulnerability of older people plays an important role in assessing this group's road safety. With a high share of 28.3 per cent, people over 65 years of age are clearly overrepresented in the group of all car occupants killed in traffic accidents.

Studies published at the national and international levels prove that sen-

sory, cognitive and motor skills are decreasing with age, but can, however, usually be very well compensated for by corresponding strategic or tactical behaviour, for instance by choosing a specific route or speed. The use of driver assistance systems may also be beneficial in this adjustment process.

The extent to which capabilities become poorer varies greatly from person to person and depends very much on a person's overall health. As some studies show, the age in calendar years is not a sufficient criterion to require senior citizens that they have their fitness to drive examined. Instead, the primary aim should be to support older people in their decision-making process and raise their awareness of possible dangers in road traffic. Pointing out the possible safety potential at their disposal – such as experience, learning ability, need for safety – and possible compensation strategies can also be instrumental in reaching that goal. Suitable measures to improve the safety of this group of road users include targeted trainings and seminars, as well as increasingly involving attending physicians in the measures. The introduction of a labelling system for medication which highlights when driving abilities may be impaired is considered appropriate. In terms of vehicle engineering, assistance systems offer older drivers a possible support, provided they are self-explanatory and not overwhelming.



Westend61 / Getty Images

SENIORLIFE study

A tailor-made approach covering a wide range of interaction pathways is required to make older drivers aware of the specific dangers in road traffic and to support them in their mobility decisions. This in turn requires precise knowledge of those psychological factors that have a significant influence on this group's decision-making process and driving behaviour. BAST's ongoing SENIORLIFE study [2], based on a representative survey of 2,066 persons 55 years of age and older, is providing new findings.

A cluster analysis resulted in identifying the following six lifestyle groups among senior citizens:

- stimuli-seeking type (12.9 per cent),
- anti-social type (19.6 per cent),
- socially active type (11.9 per cent),
- critical type (14.6 per cent),
- domestic type I (18.7 per cent) and
- domestic type II (22.3 per cent).

The senior citizens' lifestyles were defined on the basis of their preferred leisure time activities, their favourite films, their furniture and interior design as well as their personal values.

The drivers that are at the highest risk are those of the "anti-social type" and the "stimuli-seeking type". The share of people in the former group involved in an accident was about twelve per cent, while in the latter group the share was almost 14 per cent. If these two lifestyle groups find themselves in a relatively favourable situation in their lives and have sufficient financial resources, their share of people involved in acci-



Paul Bradbury/Caiaimage/Getty Images

dents can even increase to roughly 17 per cent. On the one hand, this is due to the greater number of kilometres they drive per year, and on the other their more pronounced risk behaviour, their significantly more positive estimation of their own skills and a stronger attachment to their cars.

With increasing age, compensation mechanisms become more clearly visible and are particularly present in lifestyle groups of a higher average age and among those who more frequently report physical or psychological ailments – especially of the domestic type I. They impact expectations that are road-safety relevant, in reported driving behaviour, in perceived changes in their behaviour when comparing today with the past and in perceived changes in their living conditions as compared to earlier in their lives. These groups also stand out because of their lowest share of the number of people involved in accidents.

This study's findings suggest that the focus in the developing and implementing road safety measures for older drivers should not one-sidedly be on possible age-related or disease-related losses of capabilities, but should also take into account the characteristics that are typical for the stimuli-seeking type and the anti-social type. ■

References

- [1] SCHUBERT K., GRÄCMANN N., BARTMANN A.: *Demographic shift – current state of knowledge and recommended measures to ensure the mobility of older road users*
Demografischer Wandel – Kenntnisstand und Maßnahmenempfehlungen zur Sicherung der Mobilität älterer Verkehrsteilnehmer, Berichte der Bundesanstalt für Straßenwesen, Heft M 283, 2018
- [2] HOLTE, H.: *Senior citizens in road traffic – Needs analysis in the context of living conditions, lifestyles and expectations of road safety relevance*
Seniorinnen und Senioren im Straßenverkehr – Bedarfsanalysen im Kontext von Lebenslagen, Lebensstilen und verkehrssicherheitsrelevanten Erwartungen, Berichte der Bundesanstalt für Straßenwesen, Heft M 285, 2018

Medicinal cannabis

Dr. Martina Albrecht, physician, head of the "Fitness to Drive, Driver Training and Improvement" section



Is safe road use possible?

Many diseases may have an influence on safe road use and even exclude the person from road use altogether. The ability to safely drive a vehicle can often be restored using medication therapy. However, taking medication can also have an adverse effect on a person's fitness to drive.

The question whether patients may drive motor vehicles must therefore be decided on a case-by-case basis. All road users are responsible themselves to participate in road traffic only when they do not jeopardize others. Such a decision is made after an expert consultation with the physicians treating the patient. Patients must be capable of assessing their own fitness to drive and of deciding not to drive when they are unfit.

When patients have reached a stable condition through medication, they can be fit to drive again safely with the help of that therapy. This contributes to maintaining their mobility and participating in social activities.

Cannabis is among the medication types that can restore a patient's ability to drive. It can be prescribed in cases when other therapies have failed, for instance, for multiple sclerosis or severe pain.

As cannabis can also be abused for recreational purposes, a great deal of uncertainty arose in 2017 when Germany introduced the prescription and reimbursement for medicinal cannabis flowers, as to how to deal with these patients under road transport law and in police practice – even though cannabis-based medication has been used in therapies in Germany for many years.

Commissioned by the Federal Ministry of Transport and Digital Infrastructure, BAST addressed the question of when cannabis patients can drive safely, if and how this needs to be controlled, and how a proper therapy can be differentiated from taking the same substance illegally during traffic controls by police.

Expert discussion

In May 2018, BAST hosted an expert discussion on "Medicinal cannabis and fitness to drive". Physicians prescribing medicinal cannabis in their therapies, representatives of the German Society for Automotive Medicine (DGVM) and the German Society for Traffic Psychology (DGVP) were participants in this discussion as well as representatives of administrative authorities and the Federal Transport Ministry.

The subject of the discussion was how controls can be specified and implemented to test patients' fitness to drive, in order to ensure, on the one hand, their mobility and on the other exclude jeopardising road safety should driving a vehicle safely not be possible in individual cases.

Exemption: prescribed medication

Germany's traffic control law stipulates that driving under the influence of certain substances – including cannabis – will be pursued as an offence. This does not apply, however, if the substance is taken legally as a prescription drug. This exemption is justified, because a substance that is taken to treat a disease does not have the same effect on a patient as it does on a healthy person, and if the medication is taken regularly and under medical supervision. This does not mean, however, that every patient taking medication is generally fit to drive at all times.

For the purpose of road safety, it is essential that each and every patient assesses on their own authority whether they can safely partake in road traffic. Physicians, pharmacists, and pharmaceutical manufacturers are obliged to make related information available and give patients expert advice: only then can patients take informed decisions. ■



Witthaya Prasongsin/Moment/Getty Images

Accidents involving heavy goods transport vehicles

Tobias Panwinkler, geographer, "Accident Analysis, Safety Concepts, Road Safety Economics" section



Status report as a basis for future research

Traffic accidents involving heavy goods vehicles bear a heightened risk potential due to the difference in size and mass compared to other vehicles. Heavy goods vehicles, however, are not separately coded in police records of accidents. BAST analysed the number of accidents involving heavy goods vehicles and compiled a comprehensive status report.

thirds of the accidents, most frequently a passenger car. From the group of vulnerable road users, cyclists were especially involved in accidents with heavy goods transport vehicles. In just about one quarter of all accidents with heavy goods transport vehicles, three or more parties were involved. This type showed the greatest accident severity.

truck-related accidents. Additionally, a structural analysis of the accident situations involving heavy goods vehicles produced three topics that were combined in several accident scenarios and analysed in detail. The scenarios rear-end collisions, accidents at intersections, and lane-departure accidents, and cover three quarters of all accidents involving a heavy goods vehicle. This means that the greatest potential lies in developing measures targeting these scenarios – for instance by deploying driver assistance systems. The study was conducted as a basis to develop such measures and to conduct further research of these scenarios. Data and analyses are the starting point for additional studies – such as for research on emergency braking systems. ■

Accident statistics

In 2015, 11,261 accidents occurred in Germany involving heavy goods vehicles resulting in personal injuries, corresponding to four per cent of all road accidents. 524 persons were killed in these accidents which amounts to 15 per cent of all fatalities in road accidents. A second party was involved in more than two

Analysis of the accident situation

As not all heavy goods transport vehicles are involved in accidents to the same extent, four sub-groups were defined: semi-trailer tractors, heavy trucks with or without a trailer and heavy trucks with a special body. Setting different priorities for these four sub-groups seems to be necessary to reduce the number of

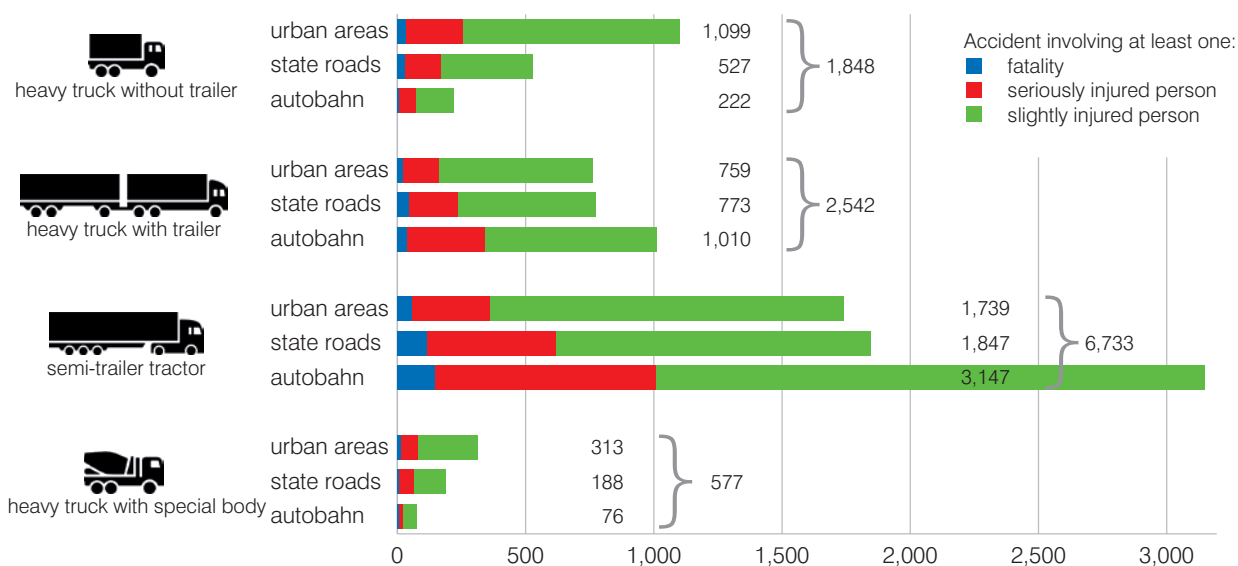

Road accidents resulting in personal injury involving at least one heavy goods vehicle in Germany in 2015, categorised by truck group, location and accident category (the sum of the four groups does not correspond to the number of all truck-related accidents; an accident involving a heavy truck without trailer and a semi-trailer tractor counts as a heavy-goods-transport-vehicle-related accident, but it is also counts as a heavy-truck-without trailer-related accident and a semi-trailer-tractor-related accident)

20 years of quality assurance in driving licence services

Dr. Astrid Bartmann, psychologist, Bärbel Dietz, psychologist, Günter Kölzer, educator, Angelika Schlüter, public administration specialist, Sandra-Bianca Schmidt-Arndt, psychologist, Ellen Schulz, office administrator, Hans-Jörg Seifert, educator, deputy head of section, Monika Stumpf, psychologist, Anke Wieners, legal assistant, Manfred Weinand, psychologist, head of the "Assessment Agency for Bodies Providing Driving Licence Services"

BAST can now look back on 20 years of successful quality assurance in driving licence services. The legal basis was created early in 1999 with an amendment to the Road Traffic Act (StVG) and the new Driver Licensing Regulations (FeV). These stipulated that service providers evaluating driver fitness, conducting courses to restore driver fitness, and technical inspection organisations (driver licence units) need to have a BAST accreditation as a prerequisite for official recognition and registration. The organisational unit "Accreditation Agency Driving Licence Services" was established as part of BAST's "Behaviour and Safety" department on 1 July 1998. In its accreditation of driving licence services BAST aimed to ensure both consistent high-quality levels in the services and a nation-wide consistency of reference standards and assessment criteria.

Assessment by BAST

After the EU restructured accreditation and market monitoring by setting up the German Accreditation Agency GmbH (DAkkS) as the sole national accreditation agency, the Federal Transport Ministry com-

missioned BAST to conduct assessments starting on 1 January 2010.

The "Accreditation Agency Driving Licence Services" was renamed as "Assessment Agency for Bodies Providing Driving Licence Services" and corresponding legal amendments were made in the same year. In 2014, following the Tenth Ordinance amending Driver Licensing Regulations and other road-traffic related legal provisions, the assessment processes and technical requirements for bodies to be assessed published until then on BAST's website, were incorporated into guidelines that are legally enshrined in Section 72 para 2 of the Driving Licensing Regulations as the basis for expert assessments.

In its quality assurance functions, BAST's Assessment Agency has the technical and process-related support of three specialist committees "Assessing Driver Fitness", "Courses to Restore Driver Fitness", "Reviewing Driver Licences". Representatives of the bodies to be assessed, lawyers specialising in road traffic legislation, independent experts and representatives of public authorities constitute

the membership in these specialist committees.

BAST's assessment procedure consists of an initial assessment after completing the analysis of the application (reviewing documentation, on-site assessments). This is followed by subsequent on-site assessments at regular intervals. The intervals for regular on-site assessments depend on the quality and stability of the service in question and may not exceed two years.

Spot checks

As a general rule, service providers assessing driver fitness are subject to spot checks in official medical-psychological reviews by BAST about three months after they start operating, within one year of their operations, and every other year thereafter. Furthermore, the competent authorities responsible for the official registration or supervision in each of Germany's Federal States can order the service providers or the technical inspection centres to subject themselves to a special assessment by BAST when such an assessment is warranted. BAST compiles a review with all the



Flowchart of BAST's assessment procedure

findings of each assessment and sends it to the service provider or technical inspection centre under review and to the competent authority responsible under regional legislation for officially recognising and supervising them.

In 2018, BAST performed additional on-site spot checks on a larger scale of the officially ordered medical-psychological reviews at 27 of the organisations listed in Section 72 of the Driver Licensing Regulations and at eight service providers assessing driver fitness.

In addition to the technical competence required to conduct an assessment of bodies providing driving licences services, BAST ensures the confidentiality, independence and impartiality that are imperative for quality assurance in the fields regulated by law. Its assessments which are one of the prerequisites for an official approval or registration by competent authorities of the service providers assessed by BAST, have proved their value as an instrument in quality assurance.

The control associated with a third-party quality assurance ensures not only that the service providers use harmonised procedures and bases for the decision-making processes in their work, but also fosters trust in the services and continuously improving them. Additionally, BAST's technical assessment of the service providers and technical inspection centres listed in Section 72 of the Driver Licensing Regulations offer the added possibility for all organisations involved to act jointly and coordinate their work to introduce optimisation measures in these sectors important for road safety action. ■



From top left: Günther Kölzer, Manfred Weinand, Hans-Jörg Seifert, Angelika Schlüter, Dr. Astrid Bartmann, Monika Stumpf, Sandra-Bianca Schmidt-Arndt, Bärbel Dietz, Anke Wieners and Ellen Schulz



Traffic Engineering

Digital autobahn: harmonisation – test – introduction

Dynamic traffic management

Innovative tool to support accident commissions

New guidelines for more road safety

Multiple safety barrier requirements

Immission control and nature conservation
across all modes of transport

BIM in the federal trunk roads sector

Fingerprint of road markings



Digital autobahn: harmonisation – test – introduction

Tobias Reiff, industrial engineer, and Karen Scharnigg, civil engineer,
"Traffic Management and Road Maintenance Services" section



C-Roads

A new generation of services in the field of adaptive traffic control is currently being tested and implemented in a real traffic environment in the scope of C-Roads Germany, which is in turn part of the European C-Roads Platform. The project began in 2016 and is scheduled to finish at the end of 2020. It is co-financed by the European Commission in the context of its "Connecting Europe Facility" campaign. Cooperative Intelligent Transport Systems (C-ITS) are based on wireless bi-directional communication between the infrastructure and vehicles. This technology enables a direct influence on road users as opposed to collective traffic control methods such as variable message sign systems that are already widely used. The interfaces are harmonised at the European level as to enable seamless communication across national borders. All eight services listed in the table below are being tested in Germany until the end of 2019. There will be Europe-wide cross tests in 2020 to ensure the interoperability of the services transnationally.

In the two German pilot projects, a total of 52 control stations and 18 vehicles were equipped with the corresponding technology to test these services. The joint technical interface is based on the wireless ETSI ITS-G5 dedicated short-range communication technology. Most of the services can be implemented using the following two types of messages: the CAM status report (Cooperative Awareness Message) and the DENM warning message

(Decentralized Environmental Notification Message). CAM messages transmitted by vehicles at short regular intervals can be received by the infrastructure; they complement data on traffic conditions acquired in the traditional way – for instance using induction loops. DENM messages are transmitted by the infrastructure system – such as maintenance vehicles or control cabinets – to the relevant vehicles, enabling an early warning to be sent to road users for them to react in time to particular incidents and adapt their driving behaviour.

Cooperative ITS corridor

The Road Works Warning (RWW) service is being implemented as an initial application of cooperative traffic systems to alert road users of temporary road works. Road users approaching a temporary road works site are informed in good time via their in-vehicle display systems. This information complements static road signage informing them about

temporary roadworks. The direct communication between road-side traffic guidance systems on the road and vehicles enables road users to anticipate road conditions and drive more safely as they are informed in good time about potential hazards.

The cooperative application of roadworks warning that was developed in the context of the C-ITS corridor showed in its test run on selected autobahn sections by Hessen Mobile that the assumptions made so far only in the context of research and pilot projects are also confirmed in real traffic conditions and operating conditions of maintenance vehicles. The communication ranges achieved in the projects were consistently evaluated as sufficient to warn road users about temporary roadworks in time. The findings show that the ETSI ITS-G5 technology has reached a level of maturity in short-range road traffic communication that enables cooperative systems to be generally introduced and regularly operated.

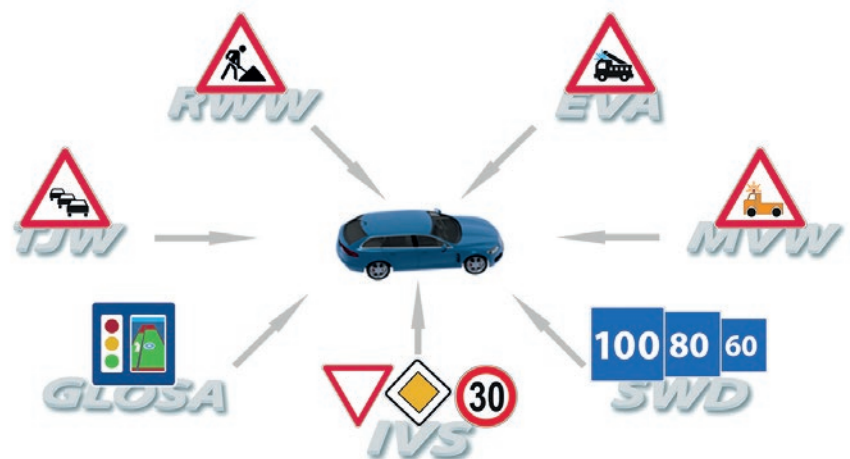

Image: © CAR 2 CAR Communication Consortium

Digital Test Field Autobahn (DTA)

In 2015, the Federal Transport Ministry initiated the “Digital Test Field Autobahn” (DTA) to test other system ideas in the context of automated and connected driving as well as smart infrastructure. Their installation and operation are a collaboration between the Free State of Bavaria, the German Association of the Automotive Industry (VDA) and the Federal Association of Information Technology, Telecommunications and New Media (Bitkom). The DTA was installed on a section of the BAB A 9 autobahn between Munich and Nuremberg that is about 140 kilometres long.

The studies on the test field can be divided into two thematic areas: “Automated and Connected Driving” and “Smart Infrastructure”. In the “Smart Infrastructure” area, various measures related to a smart infrastructure are being tested and further developed to be able to tap the full potential of a digitalised road. The “Strategic Routing” measures is part of this thematic area. It aims to make traffic control strategies from the public sector available to commercial navigation systems. The display and content of active traffic management systems and variable message signs are intended to be made available in digital form to the automotive industry and, using the mobility data market square (MDM), also to private service providers. ■

	Roadworks Warning	Before they arrive at a roadworks site, drivers receive relevant information about it. The drivers are warned about the hazard and can thus respond in good time.
	Probe Vehicle Data	The service is based on in-vehicle data that is regularly transmitted to the infrastructure at short time intervals. The data is processed and serves as a basis for additional traffic control services.
	Traffic Jam Ahead Warning	On the basis of the in-vehicle data transmitted, the end of a traffic jam ahead can be located precisely and the drivers can be warned beforehand.
	GLOSA Green Light Optimal Speed Advisory	Drivers receive individual speed recommendations to optimise traffic flow in urban areas and enable efficient driving.
	In-Vehicle Signage	The vehicles have access to immediate information about static and dynamic traffic signage.
	Shockwave Damping	Speed recommendations are displayed to the road users based on current traffic conditions to harmonise traffic flow and prevent traffic jams from growing.
	Emergency Vehicle Approaching	When emergency vehicles (for instance fire engines, ambulances) are en route, they transmit a warning signal to vehicles affected to prevent accidents and to optimise the creation of an emergency lane.
	Maintenance Vehicle Warning	Road maintenance vehicles (such as winter maintenance vehicles) transmit warning signals to vehicles near them to prevent accidents.

Pictograms: ITS mobility GmbH

Dynamic traffic management



Bentje Flick, meteorologist, "Environmental Protection" section

When air quality action plans are developed, mitigation measures are defined to comply with the ambient air quality limit values of the 39th Ordinance Implementing the Federal Immission Control Act (BImSchV). Environmentally sensitive traffic management (UVM) systems have increasingly been used for this purpose in recent years. UVM systems dynamically activate measures to improve air quality only if current measured values or projections of exceedances on the basis of anticipated traffic volumes and local environmental conditions necessitate a reduction in air pollution.

Experts studied aspects such as effectiveness, design, and the necessary alignment and adaptation processes with other traffic management systems, as well as the complexity and acceptance of ex-

isting UVM systems in a "Dynamic Environmentally Sensitive Traffic Management" study. Systems in Braunschweig, Potsdam, Erfurt and Lutherstadt Wittenberg, and an adaptive traffic control system in Styria in Austria were analysed in detail.

Findings

A survey among the operators and contracting entities of the established UVM systems showed that authorities, the private sector and citizens appreciate and accept the systems, and that they can contribute to mitigating air pollutant emissions.

A targeted deployment of dynamic UVM measures, such as making traffic run more smoothly and metering traffic flow onto autobahns, resulted in reductions of up to seven

per cent in the NO₂ annual average values of hot spots in the study areas. By using a dynamically controlled truck ban and diverting truck traffic, it was possible to reduce the exceedance of the PM₁₀ daily average by two days. The effect of the UVM measures in reducing air pollution is determined not only by local conditions, meteorological and traffic conditions but also by the UVM measure's restriction level and its activation rate. The environmentally sensitive approach thus aims to optimally align threshold values that trigger measures and the effects they create.

The research project also shows the wide range of UVM systems studied in terms of scope and complexity. Simpler systems can, however, be gradually expanded and improved and combined with already existing traffic management systems.

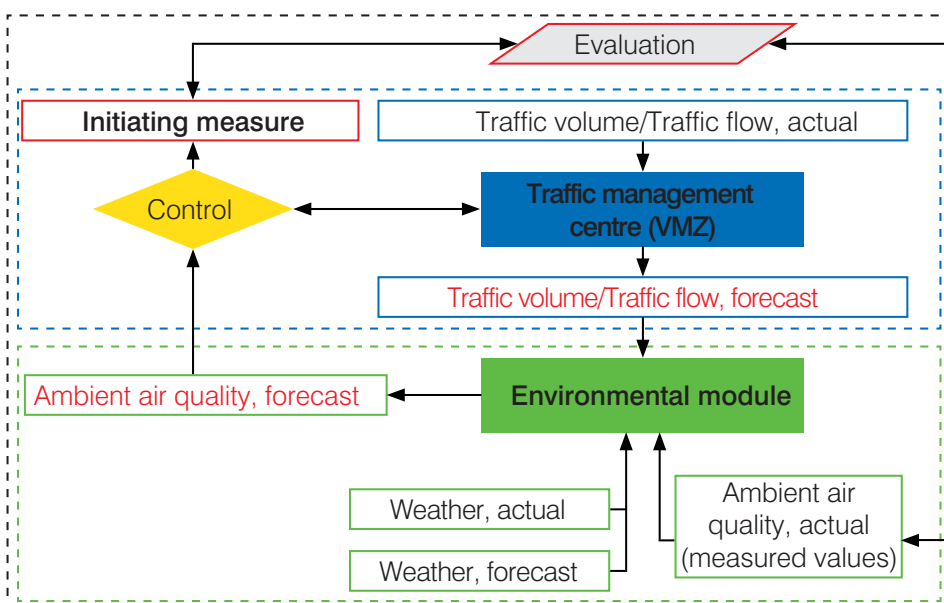

Functional diagram of a traffic management system with integrated environmentally sensitive traffic control (individual illustration based on Rule 2014:2, Effect of Measures on Reducing Environmental Pollution by the Road and Transportation Research Association (FGSV))

When UVM systems are adapted to existing local conditions, it will also be possible to combine not only individual hot spots but also sub-networks and even entire urban networks into one UVM system. Such systems can contribute to reducing the overall average of air pollution not only locally but throughout a city.

The findings of this research project were summarised in decision-making flowcharts to set up and deploy UVM systems and measures. ■

Innovative tool to support accident commissions

Dr. Marco Irzik, civil engineer, deputy head of the "Highway Design, Traffic Flow, Traffic Control" section



The European Union and Germany both have the declared aim of continuing to drastically reduce the number of fatalities and seriously injured persons in road accidents. Safety management systems for road traffic infrastructure are intended to support this goal.

Accident commissions

Accident commissions play an important role in this context. Their function is to identify places in the road network across Germany where accidents occur most frequently. Specific situations need to be evaluated and measures taken to avoid accidents. These can be structural measures or traffic-control measures. The accident commission also has to ensure that the measures agreed upon are implemented and their impact is analysed.

The accident commissions' work is based on the Factsheet on Investigating Accidents in Accident Commissions (M Uko 2012), which replaces the first part of the old Factsheet on Evaluating Traffic Accidents – Compiling and Evaluating Accident Type Maps (MAS-1, 2003 Volume).

Since early 2016, the second part of the Factsheet on Evaluating Traffic Accidents has also been updated: Measures Against Accident Blackspots (MAS-2, 2001 Volume). Measures familiar from the Factsheet were reviewed, updated and brought together with newer measures in a web-based catalogue of measures against accident black-

spots – in short MaKaU – as part of a BAST research project.

Open and closed sections

Like the previous reference catalogue, MaKaU lists possible measures to combat accident blackspots. This section is open to the public. For data privacy reasons, additional functions concerning the work of the accident commissions are restricted in a section accessible only to registered users. These include, for instance, the analysis of an accident situation at a specific location together with EDP-supported recommendations of measures and final effectiveness checks.

Innovative tool

This innovative technical aid is set up as a learning system. New measures can be added easily and it is possible to continuously update the effectiveness of old and new measures on the basis of the results of effectiveness checks supported by MaKaU. If it is widely used, up-to-date measures that are valid in the future would be made available to users at regular intervals after a quality check.

Pilot phase

Selected accident commissions have tested the MaKaU prototype that was ready for commercial ap-

plication in a pilot phase as part of a second BAST research project. On the basis of feedback, comments and suggested improvement provided by the pilot users, it was possible to further develop this innovative web application into a fully-developed tool.

Outlook

Upon completing its pilot phase, MaKaU was made available to the German Federal States in 2018. After installing the registered-users-only part on a regional server, the Federal States can authorise their state accident commissions to use it. When used widely, this web tool that has now been developed makes another contribution to improving road safety in Germany. ■



New guidelines for more road safety

Dr. Marco Irzik, civil engineer, deputy head of the section, and Bernhard Kollmus, traffic engineer, “Highway Design, Traffic Flow, Traffic Control” section, Dr. Thomas Jähig, traffic engineer, “Highway Design, Traffic Flow, Traffic Control” section until 2018, now State Ministry of Saxony for Economic Affairs and Labour, Dr. Jan Ritter, civil engineer, “Highway Equipment” section

BAST scientists are often instrumental in developing new or updated technical regulations in the context of their activities in official committees, contributing current research findings. In the reporting period, two sets of regulations were adapted to reflect state-of-the-art research and further developed taking into account experience and requirements from practice. The two sets of regulations intend in particular to improve road safety and help achieve road safety goals defined by the Federal Government.

Guidelines for road safety audits

Road safety audits are a safety management procedure for road infrastructure. Planned roads and, in the future, existing roads as well are intended to be reviewed by independent auditors regarding the best possible road safety design, identifying potential deficits so that appropriate action can be taken. The basic idea behind this safety audit is that road planning does not offer the optimum in safety for road

users just because all minimum requirements of the drafting regulations have been complied with. In addition, planning is always the result of balancing various requirements – for instance, environmental issues or with regard to traffic flow and costs.

In 2012, the “Recommendations for Road Safety Audits” (ESAS) of the Road and Transportation Research Association (FGSV) were the first set of regulations on safety audits introduced in Germany. At the end of 2017, FGSV’s responsible working groups under the chairmanship of BAST presented the “Guidelines for Road Safety Audits” (RSAS) which they further developed on the basis of the latest research findings. The RSAS now also include a safety audit for existing roads in addition to the established audit at the planning stage. Incident-related safety audits can be conducted both as a preventive and a reactive measure. Their scope includes safety checks on road sections that show a noticeably high number of accidents or on the existing road

network in the run-up to imminent maintenance measures or new constructions intended to replace old structures. The latter are currently often conducted only along the old structure’s design, missing out on opportunities to improve road safety in the course of a maintenance measure. Safety audits of existing infrastructure are intended to identify existing improvement potential in road infrastructure without disproportionate effort with the aim to implement them in the course of the maintenance measure.

Guidelines for road markings

The currently applicable “Guidelines for road markings” (RMS) were first published in 1980. As the RMS are no longer in line with today’s circumstances and requirements in essential aspects, the competent committees in the Road and Transportation Research Association have revised them completely.

The revision of the RMS aimed to update them on the basis of amendments to the Road Traffic Regulations (StVO) and corresponding Administrative Rules (VwV-StVO) that had been adopted in the meantime. The RMS, as referred to in the Administrative Rules concerning the Road Traffic Regulations as a reference connect project design-related regulations and traffic law. As markings are of relevance in traffic law, the terminology of the Road Traffic Regulations has been aligned with that of the Administrative Rules concerning the Road Traffic Regulations. The draft



Left to right: Dr. Marco Irzik, Bernhard Kollmus, and Dr. Jan Ritter

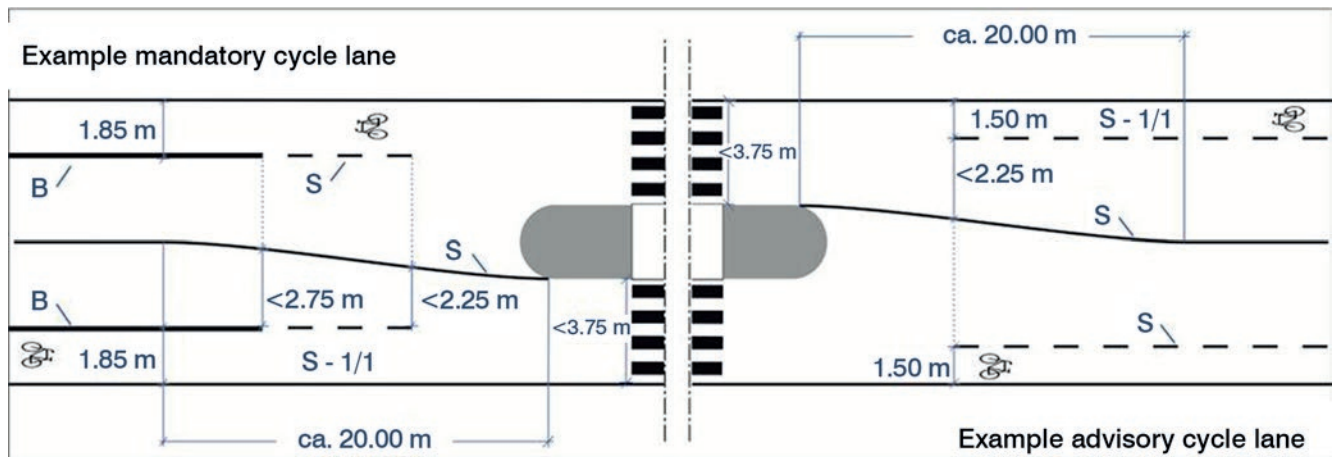

Marking of pedestrian crossings at traffic islands with different types of cycle lanes

was also the subject of in-depth consultations between the Expert Committee of the Federal Government and the Federal States on the Road Traffic Regulations (BLFA-StVO) and the competent FGSV committee.

The revision also focused on adapting the RMS to the basically new structure of project design regulations, from previously sector-specific guidelines to integrated guidelines for the following road types: autobahn, state roads and roads within urban areas. As a result of the revision, there are now separate sections of the RMS available specifically tailored to the requirements of the individual road types. The RMS deal with road markings planned in accordance with the Guidelines on Designing Autobahns (RAA), State Roads (RAL) and Roads within Urban Areas (RASt) and implement specifications of traffic law in terms of markings. Pre-defined plans illustrate the basic use of markings by using typical situations in designing roads. A multitude of examples and pre-defined plans explain the difference to project design-related regulations.

Furthermore, new technical developments such as markings for dotted advisory cycle lanes and markings for roundabout traffic were incorporated into the RMS as part of the revisions. The image below shows the example of marking pedestrian crossings at traffic islands with different types of cycle lanes.

All consultations with the Federal States and with other FGSV com-

mittees have for the most part been completed for the RMS sections on autobahns and roads within urban areas. The RMS Section on state roads was the subject of a hearing among the Federal States in early November 2018. The feedback from this meeting is being evaluated and integrated into the draft version. This will be followed by a final approval in the competent committees. ■



In the new audit of existing roads, on-site inspections are obligatory; even in the early phases of a planning-stage audit they are only unnecessary in substantiated exceptional cases

Multiple safety barrier requirements

Susanne Schmitz, civil engineer, Janine Kübler, civil engineer, head of the section, and Linda Meisel, traffic engineer, "Highway Equipment" section



Safety barriers on roads are intended to prevent vehicles from veering off the carriageway, in order to prevent serious consequences of accidents. In addition to protecting the occupants of a vehicle – mitigating accident severity, the protection of third parties, for instance oncoming traffic and pedestrians, is in the foreground. To fulfil these tasks, multiple requirements arise as a result of varying overall local conditions along the road network. Safety barriers are tested in standardised impact tests pursuant to the DIN EN 1317 European standard to identify their performance characteristics. The features thus identified – containment level, working width, impact severity – serve as crucial properties in selecting suitable safety barriers for specific installation situations. But other properties of safety barriers also play an important role for them to be safely and competently deployed at the respective location. The focus here is on the compatibility of safety barriers among each other, the handling of specific installation situations and the necessity of additional devices.

Compatibility

Not only the safety barriers themselves, but also their interconnections – transitions – need to be safe for road use and powerful in the event of an impact. BAST thus described the requirements for safety barrier transitions in the "Technical Delivery and Testing Specifications for Transitions Connecting Safety Barriers" (TLP ÜK 2017). In addition to ensuring a permanent connection, other aspects were also taken into consideration, for instance the mechanisms of both safety barriers, vehicle behaviour in the event of an impact and structural features such as continuous rigidity progression and an even transition in height and width. Transitions will be assessed on the basis of the TLP ÜK, and can be deployed as long as they fulfil the requirements. This is a vital contribution to ensure that compatible safety barriers with safe and secure connections are deployed in practice.

Special installation situations

Safety barriers are also controlled to ensure that test results on straight roads and flat terrain are comparable. However, the installation situation in reality, especially on rural roads, often significantly differs. The question arises as to what extent the test results can be transferred to curves at junctions or of especially short safety barriers. In cooperation with regional highway authorities and the private sector, BAST is therefore currently analysing these special situations

to derive requirements for special installation situations with the aim of supporting the future use of suitable and safe solutions in these situations as well.

Additional devices

At the moment, there are no binding requirements for additional devices at safety barriers – such as signage brackets, add-on delineators, anti-glare protection, curve marker posts – to ensure their safe design and implementation. This leads to a variety of elements being used whose risk potential is unclear. A working group has collected lessons learnt from regional highway authorities and the private sector and aggregated them into requirements and recommendations. These recommendations are intended as a contribution to constructing additional devices for safety barriers as safely as possible and to installing them on the different safety barriers on the basis of uniform specifications across Germany. ■



Transitions to connect different safety barriers

Immission control and nature conservation across all modes of transport

Dr. Pia Bartels, biologist, and Dr. Fabio Strigari, physicist, "Environmental Protection" section



Noise and nature do not follow administrative boundaries or responsibilities. This is why ambient air quality control and nature conservation may not be viewed in isolation. An intermodal approach is at the focus of the Expert Network of the Federal Ministry of Transport and Digital Infrastructure (BMVI).

New challenges through alien species

Landscapes along transport infrastructure are not subject to any production-oriented use and inherently have the potential to contribute positively to biological diversity. At the same time, many alien species can often be found on these pieces of land, and they spread along them. Some of these alien species grow fast and are tall, difficult to remove, or a health hazard. They can therefore pose a risk to traffic and road maintenance services. An online survey was conducted with road maintenance offices and DB Netz AG offices responsible for railway infrastructure in rural areas with the aim of getting reliable estimates of the presence of problematic species on landscapes along transport infrastructure and on the measures used to date to control and remove them. The findings show clearly that this is a problem across Germany for the two transport modes and that in many places a lot of effort is spent on controlling these species. Giant hogweed and Japanese knotweed are particularly problematic for both transport modes, as they can cause health problems and obstruct visibility. False acacia and ailanthus also lead to struc-

tural damage along railway tracks. Control measures currently in place rarely manage to completely and permanently remove existing plants. It is therefore necessary to develop maintenance guidelines to impede difficult species from settling and spreading, taking into account nature conservation requirements, but at the same time contribute to medium- and long-term reductions in effort and costs to maintain existing infrastructure and plan future installations.

Towards an assessment of total noise

As indicated by latest scientific findings, the impact of noise is one of the most urgent environmental problems of our time. A major part of humanity experiences stress from traffic-related noise due to the on-going densification of traffic – and more often than not from multiple noise sources. Analysing total noise, i.e., overlaying the noise emissions of various transport modes, is a highly topical research field of the BMVI's Expert Network, and is accompanied by representatives from road, rail, ship and air transport organisations. It aims to identify a practicable method to assess complex noise situations for an intermodal assessment, and to then compile a catalogue of measures with recommended action for optimised decisions on noise abatement which aim at reducing noise from more than just a single source. A number of different approaches are currently being tested as part of a research project – ranging from a simple physical overlaying of noise

to more complex analyses taking the impact of noise on human beings into account.

Typical noise overlay scenarios are simulated and calculated in a realistic model city – for instance at intersections between road and rail traffic. In addition, these are juxtaposed to real measurements in a research location. Diverse noise protection measures are analysed in detail in the model city, including cost-benefit aspects to find out how



A multi-lane autobahn built parallel to a high-speed line of the German railways system (Image: Ollol/GettyImages)

optimised intermodal noise reduction can be achieved. The findings of this research project will be the basis for a holistic approach that will enable finding practicable and effective solutions in the future also for noise scenarios from multiple sources. ■



www.bmvi-expertennetzwerk.de

BIM in the federal trunk roads sector

Christian Gottaut, civil engineer, and Felix Lau, civil engineer, "Surface Characteristics, Evaluation and Maintenance of Roads" section, Dr. Dirk Jansen, civil engineer, head of the "Design and Structure of Pavements" section, Gerd Kellermann, mathematician, "Traffic Statistics, BISStra" section, Thomas Mayer, civil engineer, "Steel Structures, Corrosion Protection, Bridge Equipment" section, Dr. Lutz Pinkofsky, civil engineer, mathematician and geographer, head of the "Road Construction Innovations" section, Dieter von Weschpfennig, civil engineer, "Concrete Pavements" section

Digitisation has reached nearly every industrial and business sector in recent years. The development in federal trunk roads is also highly dynamic. As early as 2015, the Federal Ministry of Transport and Digital Infrastructure (BMVI) presented its gradual plan on "Digital Planning and Building", in which applying the Building Information Modelling (BIM) work method plays a particular role.

In the form of a digital model, BIM enables every relevant piece of information about a structure to be captured, managed and shared among the parties involved for further processing for planning, building and operating purposes throughout a structure's entire life cycle.

A new research line was established with BAST's revision of its medium-term research planning 2016 to 2020. It describes the framework of BAST's research activities in the field of BIM until 2020. The concept envisages analysing the benefits

of BIM in the "operation" life cycle phase of infrastructure engineering, testing data models and continuing the development of data models taking into account standards already achieved.

Finally, examples of implementing BIM are intended to be analysed in the "operation" phase of a road structure. The "operation" lifecycle comprises all necessary structural and operational activities during a structure's service life, including conservation measures and routine road maintenance. The initiated research projects are supported by a cross-departmental BAST BIM working group.

Bridge and tunnel

Thus far, the "planning" and "building" lifecycle phases were at the centre of practical BIM applications, i.e., the phases up until a structure was completed. This is why a focus on the "operating and operation" phase aims to further explore questions about the oppor-

tunities and potential benefits BIM offers.

The completed "BIM feasibility study for existing bridges" [1] was able to show that applying BIM principles can be a suitable basis for the conservation management of existing bridges. It is also possible to integrate new data generated during the structure's use into a structural model – for instance results of inspections and sensor data.

Aspects of realising and applying BIM at an existing bridge were analysed in the "BIM for existing bridges – creating models to implement the duraBAST bridge" project (duraBAST stands for the demonstration, testing and referencing premises of the Federal Highway Research Institute). Experts created geometry models which are intended to be expanded in a follow-up project into a digital structural model in terms of BIM. The project also served the purpose of developing in-house competences and defining require-



Left to right: Dieter von Weschpfennig, Felix Lau, Dr. Dirk Jansen, Gerd Kellermann, Dr. Lutz Pinkofsky, Thomas Mayer and Christian Gottaut

ments for creating models of existing bridges.

The external “BIM in bridge construction” research project aims to develop a practice-compatible concept to support implementing the BIM work method in the operational phase, the longest time period within a structure’s lifecycle. Structural and operational measures as well as inspections of the structure and recalculations will be examined, and the benefits and opportunities of using BIM to support extending and conserving bridges will be outlined.

Tunnel structures, in contrast to other civil engineering structures, usually include a high degree of technical equipment which in turn entails a high degree of maintenance work. It is intended that efficiency benefits be gained from using BIM in the course of structural and operational measures. The “BIM in tunnel construction” project aims to illustrate the effects, requirements and opportunities in implementing BIM in the operation of tunnel structures, as well as to develop a targeted, practicable BIM concept for their operational phase, including recommendations.

Road

Viewing the lifecycle of a road structure is becoming increasingly important in the field of road construction. This is why a research project was initiated to integrate maintenance planning into the BIM system. A core issue examined in this project is assessing the significance of the high data volume against a greater level of precision in modelling the structure. At the moment, the OKSTRA® standard (object catalogue for the road and transport sector) is

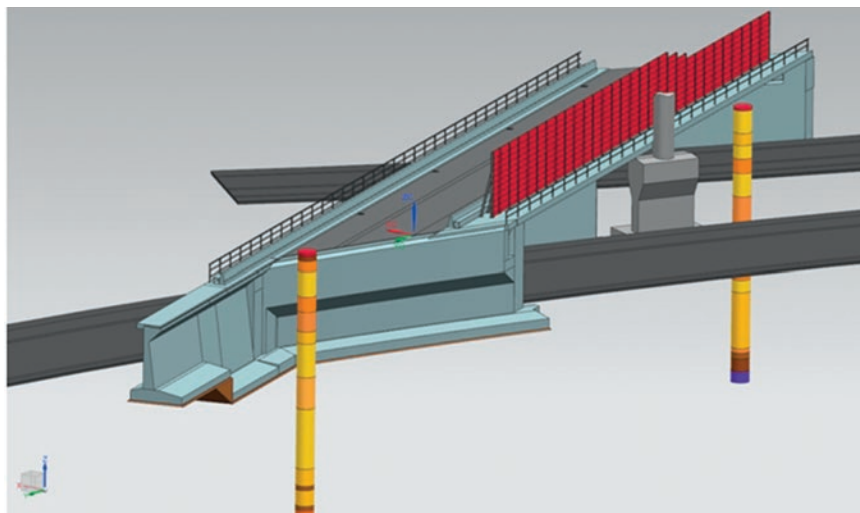

Geometry model “duraBASt” bridge

deployed in maintenance planning. This standard is designed for use in geo information systems. The research project will show to what extent an adaptation is necessary or even possible, outlining the current status quo in international standardisation efforts with regard to BIM systems in road construction, especially including Europe-wide activities. As a result, a BIM-suitable data model will be developed in the scope of the research project and subsequently implemented on the basis of lifecycle cases. The focus will be primarily on the structural maintenance of road sections.

Testing and reference grounds are available at the duraBASt site to be used for various research areas. A structured BIM platform is intended to illustrate and manage traffic areas, including all layout, engineering structures and equipment – such as installations, sensor systems, pipes, safety barriers, fences. The project aims to plan and support the activities on the site in the fields of planning, building, and operating processes throughout the entire duraBASt lifecycle using a three-dimensional model efficiently and without redundancies.

The tendering procedure for a BIM research project was initiated via the CEDR Call 2018, aiming for an efficient, high-performance data management system and a continuous flow of information throughout a road structure’s lifecycle. In spring 2019, BMI will be the subject of the CEDR Call 2019 for the German-speaking regions of Germany, Austria and Switzerland; it will run in tandem with a close link to the project in the CEDR Call 2018. The aim is to ensure an early transfer of research findings from the CEDR projects to the German-speaking regions.

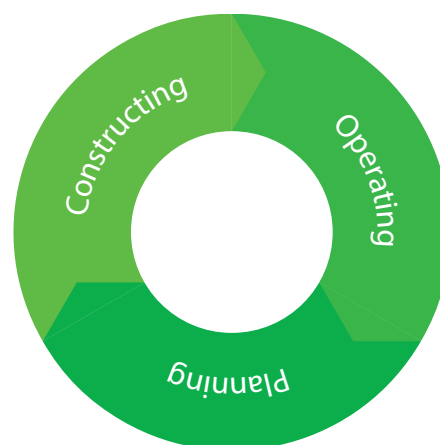

Essential lifecycle phases of a bridge

Data models

Experts from the fields of road and bridge construction define what data will be needed in a BIM project at what time and to what level of detail in a contracting party-information-specifications (AIA) document. IT departments need to make a data model available that can be used from the 3D planning phase to the construction phase, for managing the existing structure and maintenance, and, where applicable, extension planning.

For the most part, this has been successfully implemented in Germany by using OKSTRA® as it already enables an open standardised exchange between software systems from different manufacturers in the service phases of a planning process. German Federal States use this model regularly to export their data about existing structures to the Federal Information System for Roads (BISStra). OKSTRA® visually

represents the rules and regulations that the road construction sector needs to comply with. It shows graphically the objects and their properties and relations in UML and uses XML for text. Users of the OKSTRA® model can choose profile options and limit its use only to the part that is relevant for them. There are also software tools to perform a consistency check.

The complete use of OKSTRA® in BIM projects is not yet possible across the phases indicated in the picture. For a fully compliant application of BIM, it is necessary, for instance, to improve underlying sets of rules such as the instructions for the use of road information databases (ASB) which in turn is mapped in OKSTRA®. A research project has been initiated to eliminate discrepancies between the sets of rules. Should it not be possible to use the BIM method, change proposals will be developed. The aim is not only to bring

about a harmonised use of objects, their attributes and correlations throughout all lifecycle phases, but also to use solid modelling and geo information systems.

An additional study will analyse at what juncture in the planning, construction and operating processes of road construction measures the application of the BIM method can be improved. ■

References

- [1] *BIM feasibility study for existing bridges*
 Machbarkeitsstudie BIM bei Bestandsbrücken:
<http://bast.opus.hbz-nrw.de/volltexte/2017/1785>

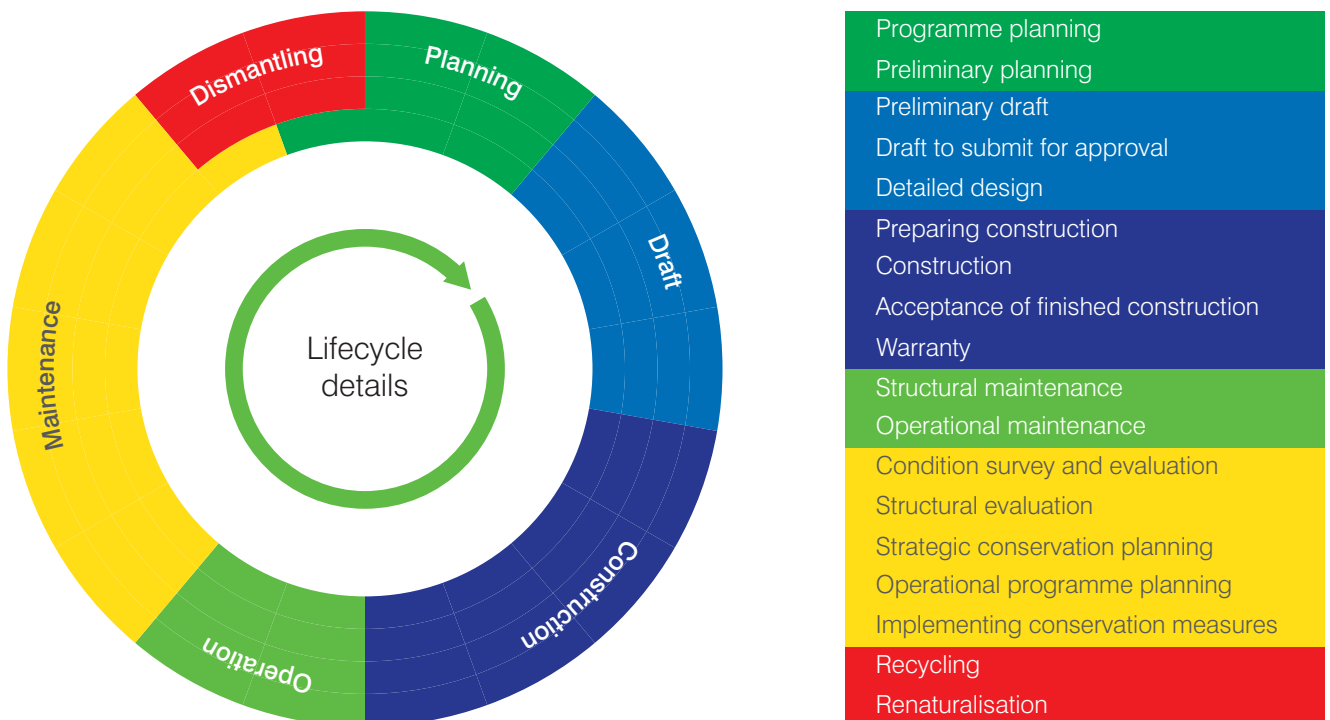

Differentiation of lifecycle phases

Fingerprint of road markings

Janine Kübler, civil engineer, head of the section, and Maike Zedler, civil engineer, deputy head of the “Highway Equipment” section
Dr. Volker Hirsch, chemist, head of the section, and Stephan Killing, engineer for corrosion protection technology and chemical engineer, “Chemistry, Environmental Protection Issues, Laboratory Services” section

The chemical composition and physical properties of road markings have an influence on their properties in traffic engineering, including visibility and skid resistance. Road markings are therefore tested not only on BAST's circular test tracks and analysed for use in traffic engineering during suitability tests, but also their original sample is subjected to chemical and physical tests. The chemical-physical tests serve the purpose of checking for banned toxic substances and of quality assurance. A kind of fingerprint can be created on the basis of these tests.

Testing sample equality

With this fingerprint, a sample equality test can show whether the marking substance used in practice is what was tested as part of the suitability test. This test includes, for instance, a comparison of the inorganic ingredients in a thermoplastic polymer. The fingerprint is defined as the reference (original sample), and the sample from practical application as the sample spectrum (sample equality specimen).

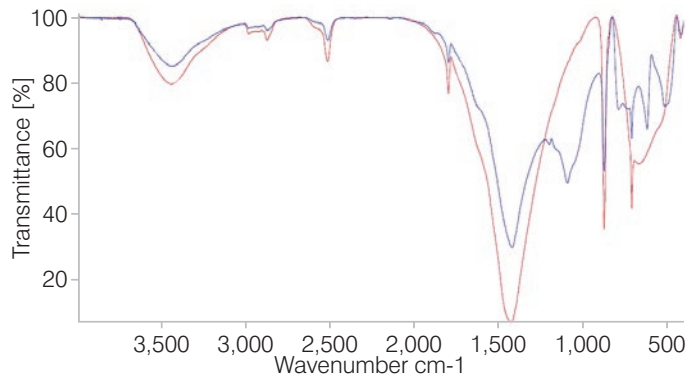

Comparison of inorganic ingredients of a thermoplastic polymer

Comparing the two diagrams in the picture shows, for instance, that the inorganic ingredients of the original sample and the sample equality specimen vary significantly from one another.

Since early 2018, manufacturers of substances have had to disclose the formulations of their marking material. With this formulation, they specify what BAST should need to determine as the material's fingerprint in its chemical-physical tests. This change in the procedure is due to adaptations to European regulations, and based on the expectation that disclosing the formulation will make deviations detectable at an

early stage, not only after the substance has already been applied to roads.

Pilot project

Comparing fingerprints generated in the past with formulations submitted later by the manufacturers was carried out in a pilot project. The pilot project's findings showed that the manufacturer's specifications provided at this point in time often significantly differ from the fingerprint values determined in the past. This is why the fingerprint values BAST identified will be used for the purpose of comparisons, i.e., sample equality tests, in the suitability tests prior to 2018.

In early 2019, as a next step, not only the road marking substances themselves but also reflective beads and anti-skid substances will be tested using a video-aided particle analysis. In this case too, the aim is to verify manufacturer information and to compare the reflective beads and anti-skid substances used in practice with those materials used in the suitability test. ■



Left to right: Janine Kübler, Maike Zedler, Stephan Killing and Dr. Volker Hirsch



An aerial photograph of a multi-lane highway interchange. In the center of the interchange, there is a circular construction site. The site contains several orange and white portable buildings, a red excavator, and other construction equipment. The surrounding area is lush green with trees and grass. The highway has multiple lanes in both directions, with cars and trucks visible. The overall scene depicts a large-scale infrastructure project in progress.

Highway Construction

Innovation in concrete pavements – surface performance
Quality-assured processes in strategic maintenance planning
New evenness indicator for contractual acceptance tests
Chemical impact of calcium hydroxide on bitumen
Load tests and economic assessment
Thermography in asphalt road construction

Innovation in concrete pavements – surface performance

Christoph Becker, civil engineer, Alexandra Spilker, civil engineer, and Dr. Marko Wieland, civil engineer, head of the “Concrete Pavements” section

With its Future Investment Programme, the Federal Government initiated a general increase in investments between 2016 and 2018. In the field of road infrastructure, its positive effects are also noticeable in research and development. For some time, digitisation (digital revolution) has been another driving force. It is being gradually introduced into the construction sector and is fostering innovations – like no other force in the economy. Digitisation needs to be seen as the driver and innovation as the targeted outcome in a process that can be accompanied and brought about by research and development. The essential question is whether an idea has sufficient potential to mature into an innovation. This needs to be clarified at the outset in an assessment of its potential.

The interaction and specific perspectives of the parties involved in road construction are increasingly gaining significance where an integrated approach is the guiding principle. The safe, efficient and sustainable use of the road as a

mode of transport can be seen as a common global objective. Besides performance and availability, only the surface of a road is of interest to users. This applies also to vehicles with driver assistance systems and future developments in autonomous driving, because the road surface is a direct point of contact for sensors which provide, for instance, information to control vehicles. It is therefore safe to assume that the quality, homogeneity and diversity of road surfaces and their performance will play an even greater role in the future. Road surfaces are thus crucial in developing pavement standards.

Top-down assessment

In BAST's concrete pavements sector, the primary focus is thus on a top-down assessment – surface, structure, construction material – in the context of an integrated, performance-oriented approach across the different processes and phases. In addition, the performance approach is the basis to transparently communicate, and objectively

consider the relevant needs of individual parties involved, using indicators for the functions and attributes of the object in question. The approach also enables integrated planning and control of quality and performance. The complexity of the “performance” aspect requires a methodological approach and adequate selection of the necessary indicators – the Key Performance Indicators (KPI).

KPI – Key Performance Indicators

As the tyre is the direct link between a vehicle and the road's surface, performance indexes, in other words, KPIs such as skid resistance, noise emission, water drainage and rolling resistance were created for road surfaces, based on the EU's tyre labelling system. Evenness is another special performance factor as it impacts driving comfort, drainage capacity, noise emission, rolling resistance and dynamic wheel load. These KPIs are used to control and describe the quality and performance of a road surface throughout all processes and phases. Other parameters or other KPIs may be necessary for communication purposes at the various interfaces of the process chains. The aim is to come up with an integrated and transparent assessment of all parameters across all processes and phases. A closed cycle is necessary for this type of assessment and targeted optimisation and control of the surface performance. A case in point is the DMAIC (define – measure – analyse – improve – control) method. In this context,



From left to right: Christoph Becker, Dr. Marko Wieland and Alexandra Spilker

measuring the KPIs is a challenge that should not be underestimated.

At the moment, only skid resistance and evenness are measured and controlled as part of the processes specified in the construction contract and during operation. As the drainage capacity is directly linked to skid resistance, this index is not assessed separately. Conventionally, the SPB (statistical pass-by) and the CPX (close proximity) methods are used to determine the sound emitted by the tyre-road surface friction (noise emission). The two methods, however, do not enable a methodological approach to concrete pavements built in slabs. This is because the transverse contraction joints are not explicitly taken into account in processing and analysing the measured signals. This is, however, necessary for a proper assessment and to optimise and develop road surfaces with good acoustic properties. This is why particularly the CPX method has been modified over the past two years and used to optimise and develop new textures during practical trials.

A washed concrete texture has been used as the standard surface for concrete pavements in the autobahn network since 2006. It offers a high level of skid resistance and shows a noise reduction capacity of -2 dB(A) pursuant to applicable regulations. As the manufacturing quality of the texture depends on a number of different conditions and parameters, it varies greatly in practice. Further improvements, particularly in reducing noise emissions are not conceivable at the moment. This also applies to the other performance indexes mentioned above, because texture homogeneity and texture depth, for example, cannot



EU tyre label and possible performance indexes, road surface with washed concrete texture

be controlled and adjusted to the extent of precision required for such processes.

Grinding and grooving technology

This is why the grinding and grooving technology – texturing hardened concrete by cutting grooves – has been the focus of systematic research and development in recent years. A technical assessment attributed a high innovation potential to this technology. It was possible to then develop texture grinding based on the performance approach. This is characterised by very high process reliability and resilience and, for the first time, enables the production of precise and reproducible surface textures in road construction. A distinction is made between “type S” (-2 dB(A) minimum) and “type A” (-5 dB(A) minimum) as regards acoustic properties.

Compared to conventional grinding and grooving, this innovative technology is primarily intended to produce surface textures of new concrete pavements which need to

comply with the exact requirements with regard to homogeneity, texture geometry and characteristics and surface evenness. To comply with this high standard, a basic evenness must be created on the road surface in a separate grinding process before the actual texturing begins. Evenness requirements of a maximum of two millimetres by four metres can be effectively realised in construction practice. The DMAIC method is used as an approach in systematic tests to iteratively achieve the optimum the system can offer for the grinding technology and for “type S” and “type A” textures with regard to their performance.

There are test sections on autobahns in various Federal States where the “type S” surface texture can be monitored. Their total length is currently about 40 kilometres of one-way carriageways.

Additional sections with a total length of more than 15 kilometres have been planned for 2019. It is intended to test the “type S+” surface texture which has more grooves in its texture than “type S”. An

above-average drainage capacity is a priority in this texture in addition to the standard factors skid resistance, noise emission, evenness.

Addressing longitudinal surface textures in measurements and characterising them by means of adequate parameters is a primary focus in the context of the aspects (DMAIC method) described above. It forms the basis for process reliability in manufacturing and for general iterative development, and will be imperative in reliable construction-contract-related processes in the future. Additionally, it would be



Road surface texture grinding: typ S+ 2.4/2.2 – 2.4/18

possible to classify road surfaces on the basis of their KPIs – using, for example, the method of efficiency categories.

Noise emissions and transverse contraction joints

Selected topics and questions will be described below which are linked to the “noise emission” surface performance. The construction detail “transverse contraction joints” is a special focus; in Germany they are standardly located on concrete pavements as slab structures at

five-metre intervals. Theoretical studies and practical application have shown that the noise-related properties of such road surfaces are more or less influenced by the acoustic effectiveness of the joints. The influence becomes greater the lower the tyre-road noise of the pure surface. This is why it was important to first create the measurement prerequisites to address the joints’ acoustics separately from the pure surface texture’s acoustics.

The noise level created in a “wheel rolling over transverse contraction joint” event depends on various boundary conditions. Cases in point are joint gap width, chamfer width and chamfer angle, position, rigidity and surface texture of the filling material, a difference in height of road surface slabs, and the rolling-over angle. A detailed and differentiated analysis proves complex, especially due to the great number of influencing factors – aspects of vehicle engineering and tyre engineering also play a role. It was possible to address surface and joint separately in the near and far fields by modifying the CPX and SPB measurement and analysis methods. As a result, a qualitative and quantitative assessment of the noise level is now possible.

Simulation calculations

At the same time, simulation calculations were performed to better understand cause and effect in the context of a road surface’s acoustic properties. The calculation model was further developed by gradually adapting and implementing relevant basic conditions. The CPX

measurements described above were an important aspect, as were the geo-referenced, digital depictions of real road surface textures, including the detail joints.

As a result, it was possible to validate the calculation results with those from the acoustic measurements and conduct a parameter study. Initial recommendations were derived from these for the construction and the material of joint structures with regard to minimising the sound pressures created when a vehicle passes by. These are the basis of an ongoing research project on the structural design of concrete pavements, the construction material deployed and the material design of joint structures (top-down analysis). The findings will also be used in revising the sets of technical rules and in optimising and further developing road surfaces with stricter requirements for their acoustic properties.

Laser scan systems

A number of measurement principles can be used as a basis to address surface textures in measurements. It is important that the measurement method is aligned towards the purpose of its use and associated questions and objectives. For measuring the textures of washed concrete and grinding surfaces, laser-scan systems (circular and linear) are currently used to be able to assess the texture design qualitatively and quantitatively. At the moment, the relevant parameter for construction contracts is medium-sized texture depth. An ongoing analysis at the test sections is intended to be used to derive parameters for longitudinal textures that are necessary for future interface communication in the process

chain or relevant in construction contracts. Their use in the manufacturing process in terms of the DMAIC method is planned for the 2019 tests. These studies will focus on issues such as the influence of changes in the texture geometry on the wear and tear of tools and creating overlapping areas in a reliable way, using laser-support in line alignments.

Three-dimensional mapping

Addressing surface textures at a two-dimensional level is not sufficient in the scientific context. A three-dimensional or volumetric analysis of the surface texture is necessary to undertake cause and effect analyses between texture and surface performance. This approach applies specifically to questions about the KPIs noise emission and drainage capacity and their behaviour throughout the surface's service life. Additionally, grinding textures have a more or less heterogeneous macro-rough ridge surface when they are manufactured.

Thus, they reach the condition that is relevant for performance assessments only after being used in road traffic for two to four weeks. The texture volume that exists then is the starting point or zero condition for the actual utilisation period and describes the so-called texture reserve. The texture conditions over time are studied in ongoing tests in conjunction with the resulting performance, as well as on the basis of loads they are subjected to in the laboratory and in situ.

Conclusion

The road surface with its micro, macro and mega texture is the primary link between pavement and tyres, i.e., the users. It also decisively influences road safety on the basis of its utilisation properties, as well as in aspects such as noise and CO² emissions. A top-down analysis is pursued to develop future concrete pavement structures in the context of an integrated, performance-oriented approach across the different processes and

phases. In combination with the DMAIC method, the future goal of controlling, optimising and developing them can be achieved in a closed cycle. The texture grinding technology is on its way to becoming a real innovation and currently is in the adoption and diffusion phase. It offers the possibility to produce permanent road surfaces with a surface performance fit for individual needs and users. From today's point of view, a nuanced integration of the different KPIs skid resistance, noise emission, water drainage, rolling resistance and evenness can be envisaged. The classification of performance indexes for road surfaces in the form of efficiency categories needs to be seen as a notional future vision and not a defined goal. ■



Laser-supported control of line alignment of grinding machine

Quality-assured processes in strategic maintenance planning

Maria Kühnen, economist, Felix Lau, civil engineer, Petra Lipke, civil engineer, Daniel Schüller, computer scientist, Frieder Seytter, computer scientist, and Dr. Ulrike Stöckert, civil engineer, head of the "Surface Characteristics, Evaluation and Maintenance of Roads" section

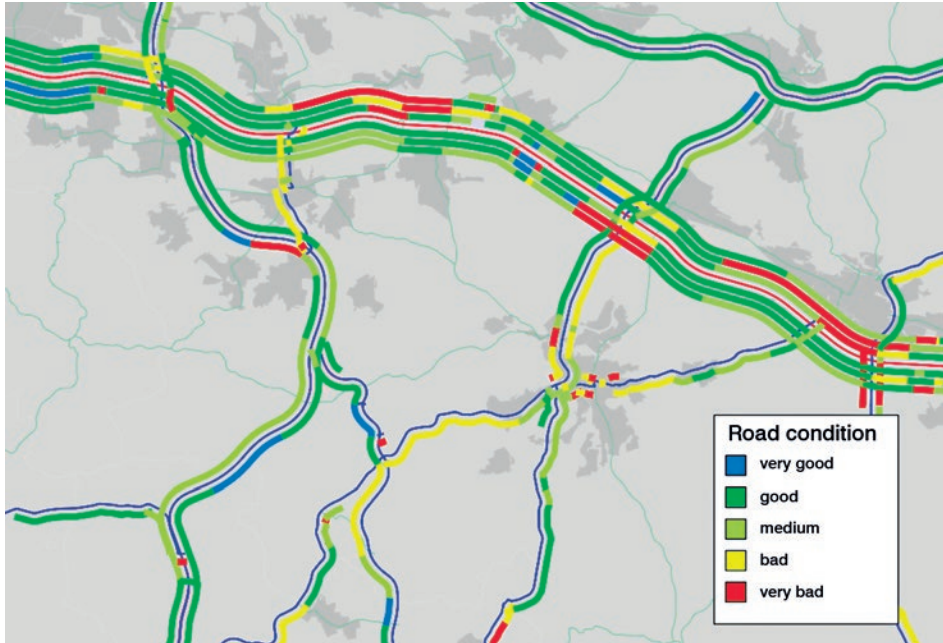

Example of a network analysis using Pavement Management Systems (PMS)

The network of federal trunk roads has grown historically and shows greatly differing development standards and age structures. A considerable part of the network was built in the 1960s and 1970s. Substance-related maintenance measures have been planned in particular for these sections over the next few years, which means there will be a significant increase

in construction activities. An assessment of the necessary maintenance requirements in the scope of strategic maintenance planning is becoming ever more important to maintain the efficiency of the road infrastructure over the long term.

Maintenance requirements are projected over the entire network of federal trunk roads. Pavement

Management Systems (PMS) illustrate the changes in a road's condition using forecasting functions to detect road sections in need of maintenance. Taking technical and economic optimisation criteria into consideration, possible maintenance measures and implementation time frames are proposed for these sections, and cost is assigned.

Quality assurance method

Last year, BAST took over the task of developing a quality assurance method to conduct this type of maintenance forecast. It includes quality control of the input data, defining and documenting plausibility checks and assessing technical approaches and model parameters for the forecast procedure.

Road condition data, traffic loads, cross-section data as well as structure and age of the existing pavement are input variables for forecast calculations. For the most part, this data can be found in the Road Information Database (SIB) of the individual Federal States. The data submitted to BAST by the Federal States was checked and found to be practically complete and of very good quality in terms of network data as well as condition-related and traffic-related data about the road infrastructure. The same does not apply to inventory data about the network of federal trunk roads (cross-section, age, structure). At this point in time, there is not yet a reliable evaluation of the completeness and quality of the inventory data.



Left to right: Daniel Schüller, Petra Lipke, Felix Lau, Dr. Ulrike Stöckert and Maria Kühnen

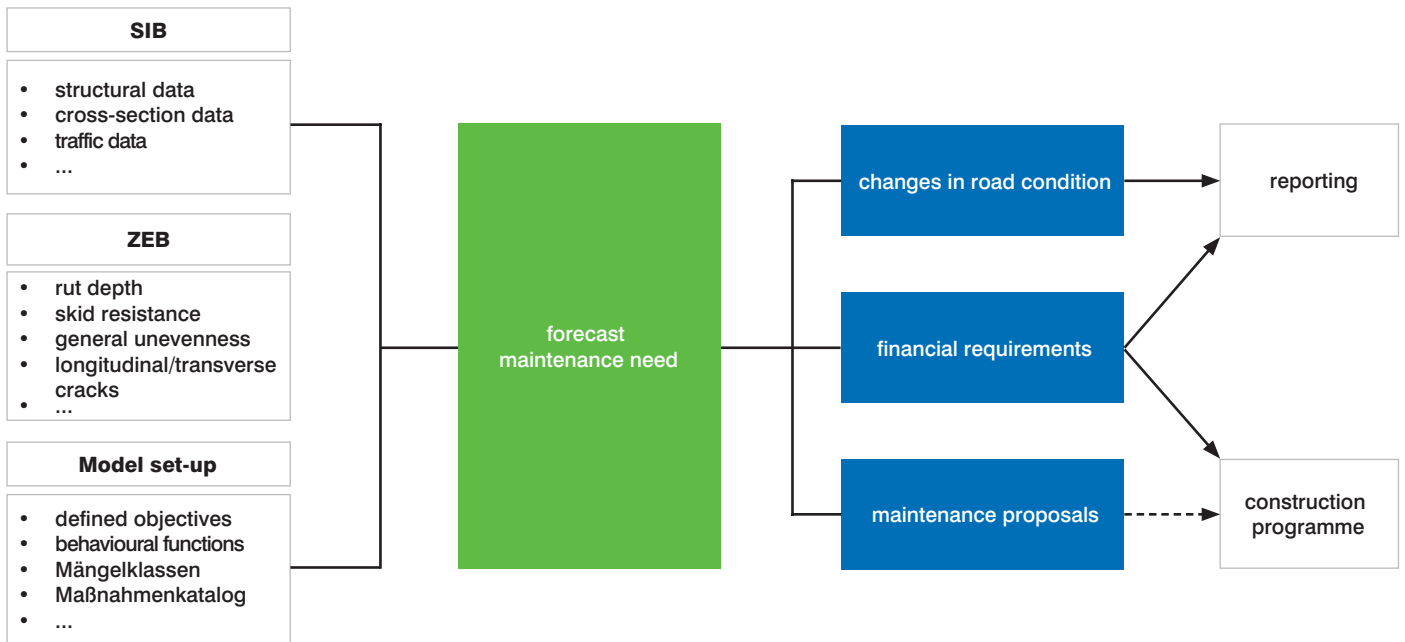

Process flow for strategic maintenance planning

Database

In 2018, BASt set up a database combining the inventory data from all Federal States. This process is highly complex, because the Federal States use three different SIB systems and a variety of data formats and models.

In the meantime, the database has been successfully established and initial plausibility checks carried out with regard to completeness, type, age, structural design. Detected gaps and unusual and deficient data will be marked, compiled in tables and visualised in maps. The Federal States will receive the results to enable them to correct their SIB systems accordingly. In the long term, a feedback system is intended to be developed with the administrative authorities to improve the inventory data. This will be an essential component for the quality assurance process. At the same time, it will now be possible to provide a reliable evaluation of the pavement structure of the network of federal trunk roads.

The model parameters to apply PMS to forecast maintenance requirements were also analysed to develop an additional component of the quality assurance process. This revealed that the method used so far is outdated and that the technical approaches urgently need to be further developed. The next steps thus focus on the question of what adaptations in the system's configuration (model setup)

are necessary and can be implemented.

The aim is to define nation-wide uniform standards for the technical approaches and processes, which in turn is intended as an elementary prerequisite for all forecasting processes, analyses and evaluations in maintenance planning. ■

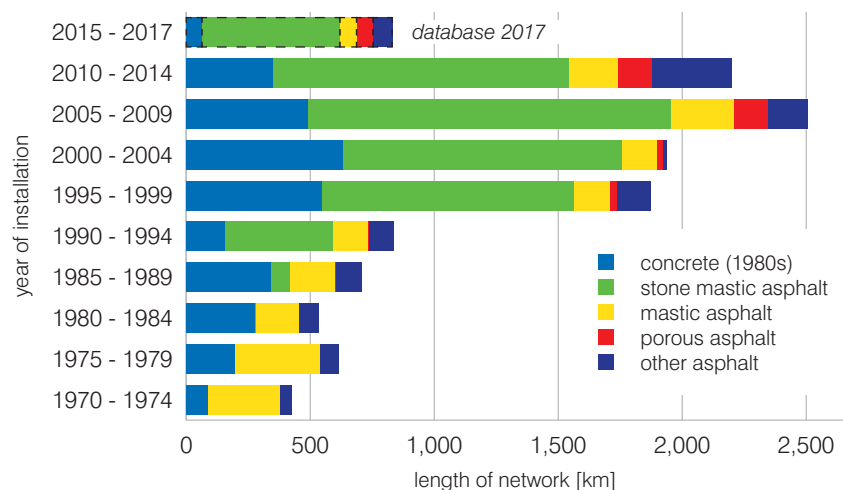

Surface pavements on federal autobahn by age structure

New evenness indicator for contractual acceptance tests

Dr. Ulrike Stöckert, civil engineer, head of the section and Christian Gottaut, civil engineer
"Surface Characteristics, Evaluation and Maintenance of Roads" section



A road's evenness has an impact on road safety and essentially determines driving comfort. In addition, the unevenness of a road leads to increased dynamic axle loads and has an adverse impact on the service life of the road pavement.

A variety of methods are currently deployed to evaluate the evenness of road surfaces. Procedures such as a planograph or a four-metre straight edge are used in acceptance tests after new constructions and maintenance work. These procedures are characterised in particular by how easily and quickly they can be deployed in practice.

In recent years, some new road sections have shown abnormalities in their longitudinal evenness. Once they were opened to traffic, road users criticised the driving comfort on these road sections. The acceptance test under the construction contract did not find any abnormalities with regard to longitudinal unevenness. This deficit was caused by brief periodic unevenness which cannot be detected using conventional methods (planograph). Against this backdrop, it was necessary to develop a new unevenness

parameter for the acceptance tests in construction contracts.

WLP – Weighted Longitudinal Profile

The new unevenness parameter "weighted longitudinal profile" was developed at the RWTH Aachen on the basis of many years of experience in evaluating road conditions. This parameter can be used to classify the different types of road unevenness that occur in practice, and then to weight and evaluate them depending on their impact on driving comfort, road condition and vehicle. Comparable unevenness parameters are already being used internationally. It was necessary, however, to develop a parameter that related to the standardised processes in Germany to provide reproducible results independent of the measuring speed, and locate any existing unevenness during the acceptance tests of a construction measure that can be used in claims for defects if necessary. The WLP unevenness indicator can fulfil all these requirements.

Corresponding prerequisites need to be created when incorporating a

test procedure or a new parameter into the technical sets of rules with contract-relevant consequences. In collaboration with various research partners such as the RWTH Aachen, Lehmann & Partner, the University of Stuttgart and many others, the WLP has been continuously further developed. As of last year, the calculation of the WLP can be found in the German and English versions of prEN 13036-5:2017.

On the basis of the findings so far, this year it has been possible to describe requirements for the measurement system, its implementation and the evaluation of measurement results, and measurement values to be taken into account in revising the technical rules. At the beginning of next year – after three years of research –, the "Expanding the use of evaluated longitudinal profiles to be used in construction contract-related applications and comparison with the conventional acceptance procedure" project will be completed.

This creates the framework for future acceptance procedures of new constructions and maintenance work using WLP. BAST and the Federal Transport Ministry are initiating a project at the moment to give all parties involved in the process the possibility to gather experience using this new parameter. In this project, measurements on the basis of the old (planograph) method will be compared to those of the new (WLP) method. The aim is to prevent in the future periodic unevenness that arises already during the construction process. ■



Methods to detect longitudinal unevenness: MEFA (multi-functional detection system for road surface analysis) (left) and planograph (right)

Chemical impact of calcium hydroxide on bitumen

Dr. Volker Hirsch, chemist, head of the "Chemistry, Environmental Protection Issues, Laboratory Services" section



In 2018, BAST conducted extensive studies on recovered bitumen and fillers as commissioned by Rijkswaterstaat (Netherlands). The fillers studied contained calcium hydroxides / calcium carbonate mixtures (hydrated lime).

One of the findings was that calcium hydroxide adsorbs polar compounds on its surface selectively and irreversibly. The adsorption of bitumen content on calcium hydroxide can be visually detected already when it is mixed with bitumen and then toluene is used for multiple extractions. The adsorbed content can be recovered after an acid treatment. As the residue is dark in colour, this is an initial indicator that it must contain asphaltenes and/or polar bitumen content. Proof can be unambiguously provided using the TLC-FID method ("latroscan") which show that only polar bitumen content, and to a smaller extent asphaltenes, are adsorbed on calcium hydroxide. The adsorption of polar compounds that increase viscosity and of heavily polar asphaltenes leads to a slight depletion in the bitumen phase of these components. Accordingly, recovered bitumen should be lower in viscosity than original bitumen. However, this effect is compensated by the integration of calcium ions and nano-scale calcium hydroxide particles into the bitumen matrix.

The adsorption of polar components also removes easily oxidisable bitumen components from the bitumen phase. Since more oxidation-resistant sections tend to remain in the bitumen phase, it seems

plausible that there is a delay in the bitumen aging process caused by calcium hydroxide.

The structural setup of the calcium hydroxide particles that are coated with polar compounds and asphaltenes is comparable to oversized "micelles" of the conventional colloid-chemical bitumen model. This is why the particles can fit themselves perfectly into the bitumen matrix.

Calcium hydroxide has a significantly greater impact on the bitumen's consistency than other mineral fillers, although it can be assumed they are well compatible with bitumen. An overdose, for instance, will have an adverse effect on the asphalt's properties. The adsorption of polar compounds on calcium hydroxide will, for instance, lead to a depletion in the bitumen phase. Since above all the polar components are responsible for the bitumen's adhesive capacity, a reduction of those proportions will lead to a drastic decrease in adhesiveness. At the same time, the mortar's viscosity increases dis-

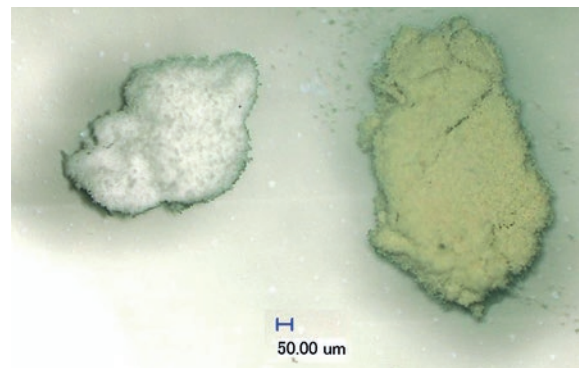

Calcium hydroxide after bitumen contact and multiple extractions (right) – as a comparison: calcium carbonate (left)

proportionately compared to conventional fillers due to an increased interaction of the particles coated with polar components among each other. This effect only occurs at very high calcium hydroxide content but this aspect still needs to be taken into account in construction practice. Calcium hydroxide differs essentially in its chemical properties from the chemical properties of conventional fillers. Generally speaking, calcium hydroxide has a "modifying" effect on bitumen, and a positive effect can indeed be expected with the optimum dosage, especially in terms of the durability of porous asphalt. ■

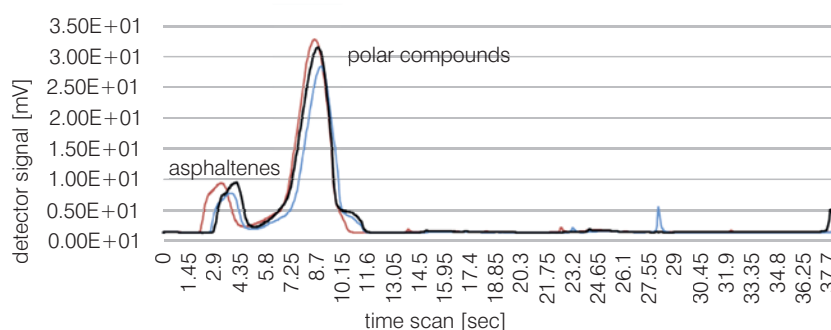

TLC-FID chromatogram of adsorbed bitumen proportions

Load tests and economic assessment

Bastian Wacker, civil engineer, "Design and Structure of Pavements" section, and Tobias Panwinkler, geographer, "Accident Analysis, Safety Concepts, Road Safety Economics" section



Since October 2017, BAST has been operating its Demonstration, Investigation and Reference Area (duraBAST). The demonstration and investigation sections are located at the centre of the area. Road constructions at a 1:1 scale have been installed there and can be tested.

BAST uses the Mobile Load Simulator MLS30 in its tests to enable time-compressed simulations of the loads from heavy goods vehicle traffic, with up to 6,000 roll-overs per hour using four commercial truck wheels with a wheel load from 45 to 75 kilonewtons.

During the initial project phase, tests were performed using the Accelerated Pavement Testing (APT) time-compression programme in five of eight completed projects. The projects included BAST's own research projects and projects funded by national and interna-

tional third parties. The MLS30 was used for a total of about nine million roll-overs within 14 months in load-related tests of joint transitions between precast concrete slabs (HESTER among others) and sealing variations for core extraction points in addition to self-healing asphalt (HEALROAD) and road constructions for energy production (SEDA).

Every APT programme consists of various elements. These include a research infrastructure with the corresponding projects, loading facilities such as the MLS30, but also standardised test programmes with different measuring systems, such as measurements for load-bearing capacity and transverse evenness.

The EU's HEALROAD is presented below as a case in point and the load programme is described.

HEALROAD – self-healing asphalt to extend the service life of asphalt pavements

From late 2015 to mid 2018, the HEALROAD project team from Spain, the UK, the Netherlands, Belgium and Germany researched the use of induction energy as a maintenance measure for asphalt pavements. This is intended to trigger the self-healing effect of asphalt in a targeted manner.

In the project funded in the ERA-NET Plus Infravation Call 2014, laboratory tests were conducted in Spain and in the UK to analyse asphalt formulations with project-specific additives and the impact of induction energy. One essential component in this project was a large-scale testing area (50 x 5 metres) with an open-porous HEALROAD pavement built on the duraBAST.

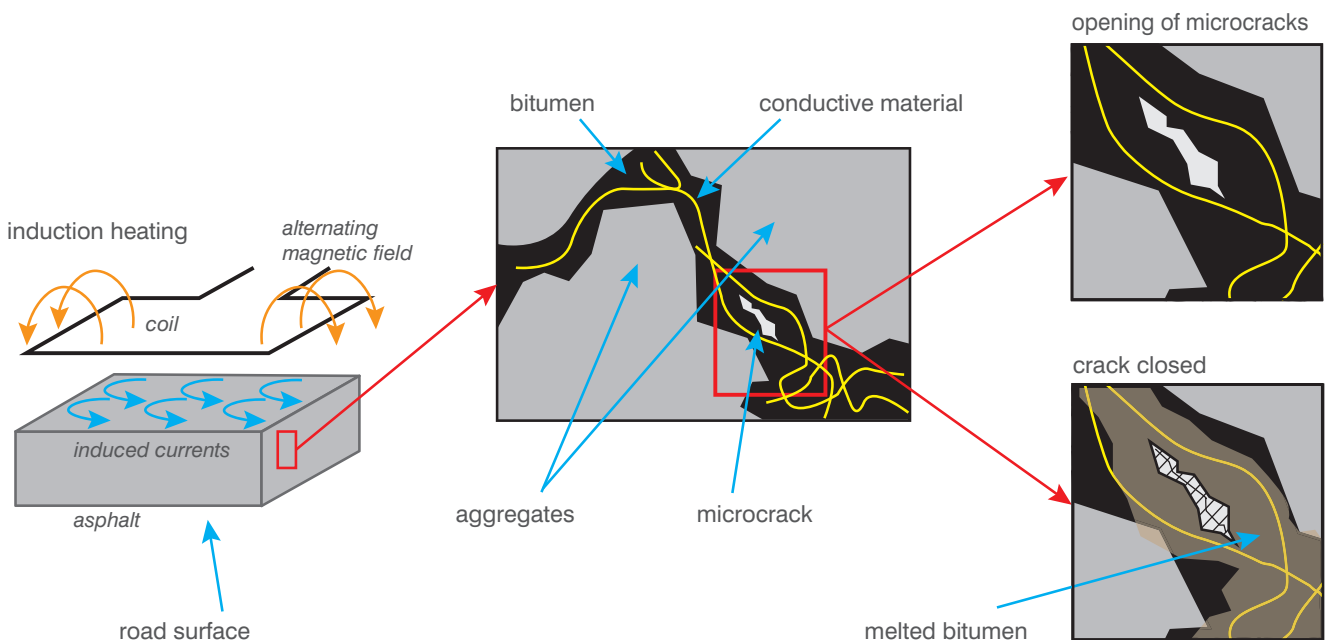

Schematic diagram of a general maintenance measure



Overview of the central area of the duraBAST

The project team defined the breaking up of the granular structure as the relevant damage case. The load programme using the MLS30 therefore deployed the highest possible wheel load (75 kilonewtons) and a continuous side-shifting to initiate shear forces. All rock pieces breaking off the surface were analysed with regard to location and quantity. The strained surface was stimulated to heal itself at defined locations using HEALROAD induction technology. The evaluation of the heat distribution was used to confirm that the innovative top layer was reconstructed homogeneously in compliance with the requirements. The results also suggested that there are correlations between the use of the induction energy and grain loss, but it was not possible to determine significant correlations in a large-scale test. The pre-defined duration of load application by means of the MLS30 is assumed to have been insufficient. It was possible, however, to demonstrate the positive effect of the HEALROAD technology in additional tests on a laboratory scale of the samples taken from the duraBAST site.

Life-Cycle Cost Analysis

A Life-Cycle Cost Analysis (LCCA) was conducted for an economic assessment. Not only the manufacturing costs of a road construction, but also its total cost during its life cycle was taken into account, and the costs for the public authority in charge of the construction, including maintenance measures and residual value, were analysed in a dynamic investment calculation. The aggregate costs of the maintenance measure took the user costs into account as well as the costs for the general public. It became apparent that the HEALROAD material is only marginally more expensive in manufacturing than conventional material because of longer mixing times and the additional induction material. The service life of a pavement can, however, be extended by using the induction technology. This would lead to a reduced number of maintenance measures and thus fewer interventions in traffic flow, and ultimately to cost savings.

The experiences from the HEALROAD project have had an imme-

diante impact for BAST on planning and designing further time-compression load-based programmes at the duraBAST, as well as on the evaluation of measured results and the economic analysis. ■



www.durabast.de

Thermography in asphalt road construction



Jan Ork, civil engineer, "Asphalt Pavements" section

Thermography is a thermal imaging procedure to measure and visualise a material's surface temperature. This is possible because the intensity of electro-magnetic radiation is proportional to an object's surface temperature. The intensity of the radiation is converted into temperature values, taking into consideration material-specific emissivity.

Practical application in research

Asphalt is a construction material that is transported and installed as a hot-mixed substance at temperatures over 140 degrees Celsius, and then cooled down to the respective ambient temperature. The cooling process depends on the material, installation thickness, sub-surface and ambient temperatures, wind conditions and other factors. A characteristic feature of rolled asphalt is that the material is finally compacted by rolls rolling over it. The processability and thus also the compactability of an asphalt mixture is heavily temperature-dependent. A homogeneous temperature distribution is necessary for a uniform quality of the asphalt layer.

Thermal imaging enables measurement of the temperature distribution of already installed asphalt surfaces and their visualisation on site. The temperatures measured are displayed as false colours and can be overlaid with purely visual images.

The picture shows an asphalt surface immediately after installation, the red frame marking the area recorded by the thermographic camera. The overlaid infrared image shows the temperature distribution using colour codes, the temperatures here range from dark blue (126 degrees Celsius) to white (166 degrees Celsius). The measured temperature range is 40 Kelvin and indicates irregularities during the installation process. A computational analysis can be performed in addition to a purely visual analysis of the thermal image to determine average temperatures, minimum and maximum values, and frequency distributions.

Asphalt pavers can be additionally equipped with infrared cameras that continuously scan the freshly installed asphalt behind them. This cross-section always illustrates a

moment immediately after installation but before the final compacting takes place with the rollers. It is not possible to determine or visualise the downstream cooling process of a particular point with it. For this purpose, a stationary infrared camera is necessary, recording a specific construction section across the entire cooling down process. This would result in time series for complete cross-sections providing insights into the cooling behaviour. The illustration on page 59 shows the progression of surface temperature of a selected measurement area for a period of about three minutes.

It can be seen that the surface temperature was 157 degrees Celsius immediately after installation and dropped over the following two minutes by about ten Kelvin to 147 degrees Celsius. The measurement was disrupted by a person walking through the picture, recognisable in a temporary drop in temperature. After about two minutes, the compacting vehicle rolled over the surface for the first time, reducing the surface temperature by another 17 Kelvin to 130 degrees Celsius after



Tested image detail in the visual range (left) and the infrared range (right)

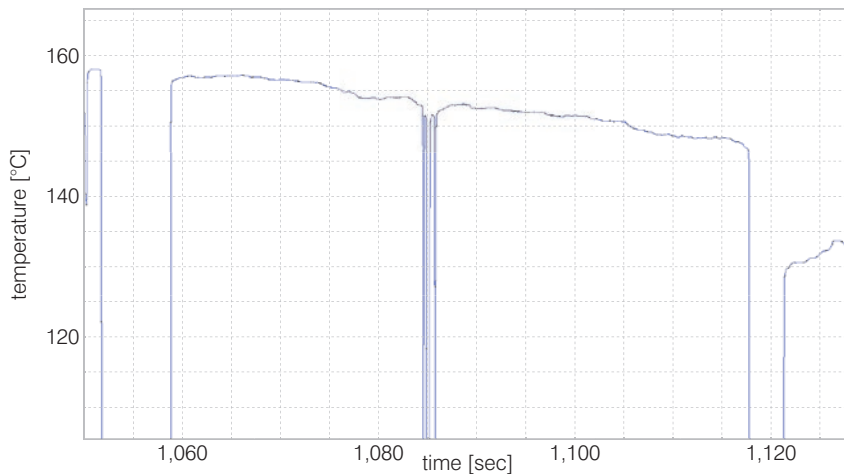

Changes in surface temperature three minutes after installation

about two minutes. The surface temperature then increased again because of the higher temperature within the asphalt layer.

While deploying a scanner directly at the paving screed can be helpful for construction measures, stationary thermal imaging is better suited for scientific studies – such as to what extent wetted compacting rolls can lead to an abrupt cooling of the asphalt surface.

Thermography at the laboratory

At the laboratory, thermography offers the possibility to analyse thermal processes. When the bonding agent was extracted in a rotary evaporator, condensation was observed at a spot where it is not wanted. The vapour from the distillate cools down too quickly and falsifies the test result due to the solvent returning. In the process of optimising the test, a heating rod was inserted into the rotary evaporator to heat up the vapour again and shift the cooling point to the optimal point. To do so, a uniform temperature distribution is aimed for along the heating rod, controlled

by a temperature sensor at the tip of the heating rod. Thermography is especially suited to review the temperature curve along the heating rod as it looks at the entire heating rod and at the same time maps the complete test period.

An adhesive tape with known emissivity was applied to enable determining the temperature curve on a metal surface in an indicative way. The heating rod was covered with the adhesive tape along the entire

heated length and also in the direction of the thermal camera. The regulated temperature was set to 200 degrees Celsius under atmospheric conditions. The illustration shows the temperature curve along the heating rod, with the temperature-controlled tip on the right hand side. Immediately behind the tip, the temperature increases to up to 280 degrees Celsius and remains in that range until the end of the heated section. This leads to the conclusion that the use of a temperature sensor located at the tip of the heating rod is not suitable for the task to be fulfilled without taking corrective measures.

Conclusion

Thermography offers diverse possibilities to gain time- and location-specific temperature values to answer questions about asphalt technology during its use on site or at a laboratory. This technology will become more important in the future, in particular in the case of a temperature-dependent construction material such as asphalt. ■

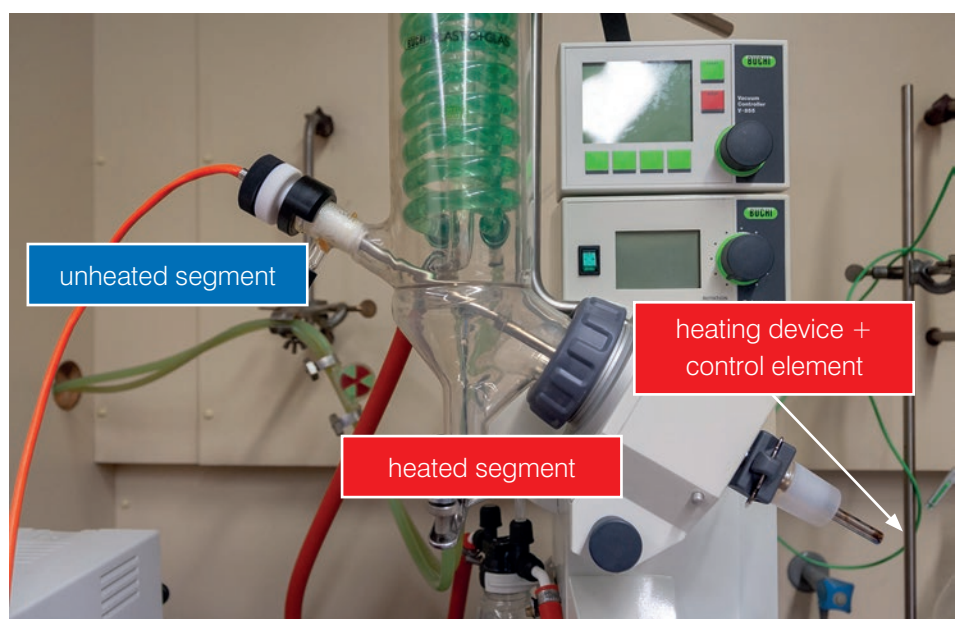

View of heating rod in rotary evaporator



Bridges and Structural Technology

Cyber-Safe

Shear strength of prestressed concrete bridges

Expansion joints – developments in Germany and Europe





Improving cyber security in tunnel and traffic management centres



Traffic and tunnel management centres are neuralgic points for maintaining the availability of road networks, as they monitor and control the traffic on roads and in tunnels. A multitude of information and communication technologies are deployed for this monitoring and control function, thus making them potential targets for cyber attacks. The Cyber-Safe research project, funded by the Federal Ministry of Education and Research (BMBF) and coordinated by BAST, intended to enable the operators of tunnel and traffic management centres to evaluate their IT security and implement suitable protection measures.

Background

With the entry into force of the first ordinance amending the Regulation on Critical National Infrastructure of the Federal Office for Information Security (BSI-KRITIS) [1] in June 2017, operators of critical infrastructure in the transport sector have been obligated to fulfil a minimum standard in their IT security and to continuously improve it. Generally speaking, this regulation covers facilities such as traffic control and management systems for the German federal autobahn network. At the municipal level, a threshold value of 500,000 inhabitants in a regulated system was defined. Even though some operators are not subject to this regulation, research and interviews with experts conducted as part of the Cyber-Safe project, have shown that

precautions should be taken proactively: in 2015 the Carmel tunnel in Haifa (Israel), which is roughly nine kilometres long, had to be closed for eight hours as a consequence of a hacker attack, leading to severe traffic disruptions [2]. In addition, against the backdrop of the developments in the field of smart traffic infrastructure, it can be assumed that these will increasingly become the focus of cyber attackers.

Approach

The Cyber-Safe project aimed to develop tools and guidelines to enable operators of tunnel and traffic management centres to detect their vulnerability to cyberattacks in a much more targeted manner than previously and to take adequate protection measures. As part of analysing the status quo in management centres, measures already implemented were checked for effectiveness, identifying deficits that may exist at the same time. As a supplementary measure, experts conducted an in-depth penetration test which produced illuminating insights into IT security.

Two workshops with operators, suppliers of technical equipment, and planners of tunnel and traffic management centres were hosted with the intention to support immediate practicability and high acceptance. The demand was identified as well as requirements for tools with which to evaluate the IT security in place and to enhance resilience against cyber attacks. The findings with regard to

user needs resulted in the development of three target group-oriented tools. These were presented to the end users at a concluding event at BAST in June 2018 and made available for immediate use in practice.

A "virtual management centre" developed during the project as a test environment enables operators to test new components, simulate targeted attacks on the management centre's IT, and test the effectiveness of relevant countermeasures.

Tools and manuals

The practical aid that was developed consists of three software tools and a manual. They were developed taking into account the catalogues for baseline security of the Federal Office for Information Security (BIS) and the ISO 27000 series, and are tailored to the needs of a total of three different target groups in terms of content and level of detail.

1. Check list for top management level

The top management level makes the necessary financial and human resources available. These managers are usually not IT experts. They rely on the support of IT experts to both evaluate existing IT security and take decisions on measures to implement. "Checklists" were developed for this target group, which is a compact browser-based software that monitors the implementation of important overarching topics. It consists of a total of 20 questions about measures already implemented.

2. Manual and evaluation software for middle management level

The middle management level mainly deals with specific organisational and human resources-related aspects. The managers have extensive technical knowledge of the management centre's IT, but often not of all aspects of IT security. A manual and accompanying evaluation software were developed for this target group, which checks whether diverse measures related to technology, organisational structure, and human resources are in place. However, these tools and manuals do not automatically identify weak spots, but they can be used iteratively to evaluate and thus gradually increase security levels by including additional, practicable measures.

3. In-depth analysis software for IT managers

IT managers have both detailed knowledge of the IT structure and knowledge of the organisation and human resources-related aspects that need to be considered. An analysis software was developed for this target group to be used as a basis for an in-depth analysis of the existing IT structure. The software creates a model-like illustration marking at-risk components and connections. In this regard, it complements the tools and manuals for the middle management levels described above, while at the same time serving as a planning aid for suppliers of technical equipment and planners.

Summary and outlook

The findings of the Cyber-Safe project show clearly that it is necessary to recommend a minimum protection level for tunnel and traffic management centres. At this point in time, planners, suppliers of tech-

nical equipment and operators have only limited knowledge, not that which is required in order to take suitable protection measures into account at the planning phase and to attribute the necessary significance to them during the subsequent operational phase.

It was possible to raise the needed awareness among the target group already in the course of the interviews with experts and workshops. Their interest is indicative for the conclusion that the tools and manuals will find their way into day-to-day practice. The current legal situation following the amendment of BSI-KRITIS is very likely to accelerate this process. The tools and manuals have the advantage of having been developed on the basis of the specifications of the Federal Office for Information Security (BSI) and adapted and specified for the particular conditions at management centres.

The Cyber-Safe research project was funded by the Federal Ministry of Education and Research as part of its "ICT 2020 – Research for Innovation" research programme. The consortium was headed by BAST, and the following partners were involved: Regional Road Construction Service North-Rhine Westphalia, Autobahn Management Office Hamm, STUVA e.V. Research Association for Understand Transportation Facilities and the Horst Görtz Institute for IT security at the Ruhr University in Bochum. ■

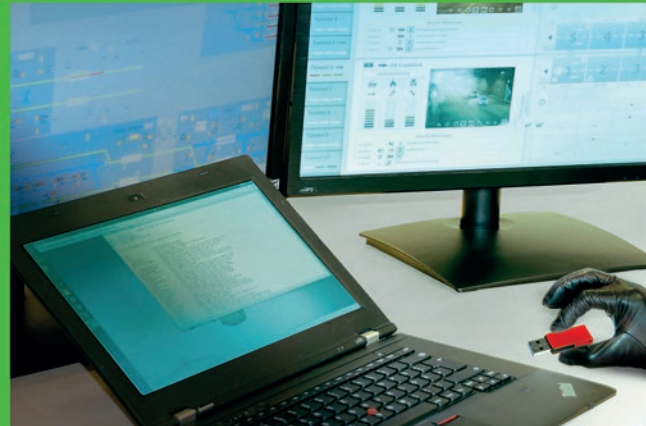

Cyber-security of tunnel control centers
Guide for the assessment and improvement of IT-security

References

- [1] *First ordinance amending the BSI-KRITIS Regulation in the promulgation version of 29 June 2017 (Federal Law Gazette, page 1921)*
Erste Verordnung zur Änderung der BSI-Kritisverordnung in der Fassung von der Bekanntmachung vom 29. Juni 2017 (Bundesgesetzblatt Seite 1921)
- [2] The Associated Press: 'Hallmark of a New Era' // Haifa Tunnel Paralyzed by Cyberattack, Expert Reveals. In: Haaretz (Archives). updated 27 October 2013. <http://www.haaretz.com/israel-news/1.554729> (retrieved on 6 November 2018)

Shear strength of prestressed concrete bridges



Dr. Matthias Müller, civil engineer, "Concrete Structures" section

The majority of bridges in the network of federal trunk roads was planned and constructed as prestressed concrete structures – including many large valley bridges. For the most part, they were built already between the 1950s and 1970s. During this time, this type of construction, which was then new, was significantly developed further.

The gradual further development of this type of construction and of the certification formats changed the construction rules that intend to lead to a more robust structural design. However, the safety required often cannot be verified on the basis of the rules and regulations currently applicable when it comes to assessing the load-bearing capacity of older bridges – and this has become necessary due to a considerable increase in heavy goods vehicle traffic in the network of federal trunk roads.

Recalculation guidelines

This is the why, in 2011, the Federal Transport Ministry (BMVI) published the "Guidelines for recalculating road bridges" (NRR). For the first time, a uniform nation-wide basis was created to assess the load-bearing capacity of existing older road bridges. The application of the recalculation guidelines is fundamental to the BMVI's bridge modernisation strategy for the structures in the network of federal trunk roads. BAST's research findings constitute the basis for the rules of the recalculation guidelines. The effectiveness of the tools of the recalculation guidelines are continuously analysed, and potential is identified and quantified in research projects to optimise the assessment of the load-bearing capacity; they are then made available for practical implementation as part of updating the guidelines.

In recent years, the certification formats that are decisive to assess the shear strength of existing prestressed concrete bridges have been further developed as part of experimental and theoretical research projects to account for the special features of existing structures and to computationally activate the load-bearing reserves. The research findings below will be made available for practical implementation during the upcoming drafting of the second revision to the recalculation guidelines.

Determining the shear load and torsion capacities of older prestressed concrete bridges

Various aspects of the load behaviour under combined shear and bending stresses, in other words, combined shear, bending and torsional stresses were studied in the scope of a research project [1]. Prestressed two-span beams and beam sections were studied that, as regards geometry and load situation, represent a section – also designated a substructure – of a two-span beam.

The experimental test set-ups used at the RWTH Aachen and the Technical Universities of Dortmund and Munich are shown in the picture. In addition to experimentally determining the load-bearing capacity of prestressed concrete bridges under shear forces and simultaneously occurring bending loads, the influence of various load configurations (concentrated and uniform loads) and of additional torsional stress

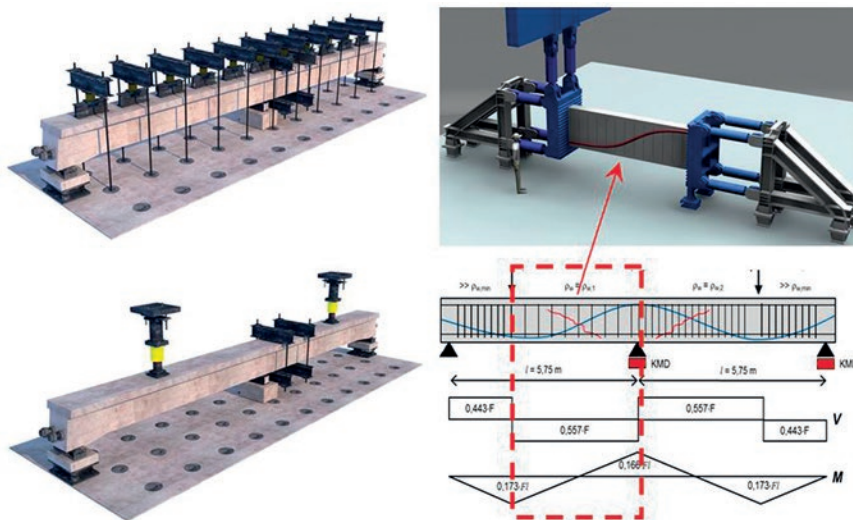

Left: Schematic illustration of the experimental set-up using two-span beams with uniform and concentrated loads (TU Dortmund, also at RWTH Aachen), Right: Beam section for substructure test and stress loads on two-span beam (TU Munich) [1]

and shear reinforcements no longer permissible today were subjects of the studies. Substructures were used for tests to study the latter.

The findings of the tests not only confirmed the assumption – which has existed since the beginning of developing strut-and-tie models to measure shear forces – that there is a concrete load-bearing portion exceeding the load-bearing effect of stirrups. It was also possible to quantify it using a calculation approach that is suitable for recalculating purposes. The truss load-bearing proportion is extended by adding a uniform concrete load-bearing proportion which corresponds to the bending shear strength of a structure without shear reinforcement. The illustration shows a comparison of the test beams' load-bearing capacity that was determined depending on the level of reinforcement. It is clear that the result variances are reduced with an increasing level of reinforcement, while forecasting accuracy increases when either method is used, i.e. when the currently applicable assessment approach is deployed or the approach proposed for further developing the recalculation guidelines.

The assessment proposal to supplement the recalculation guidelines provides improved consistency with the tested loads across all the reinforcement levels studied. Compared to the current assessment approach, more accurate results can be achieved, especially for low shear reinforcement levels that are standard when assessing older prestressed concrete bridges.

Besides expanding the verification formats for assessing shear forces described above, it was also pos-

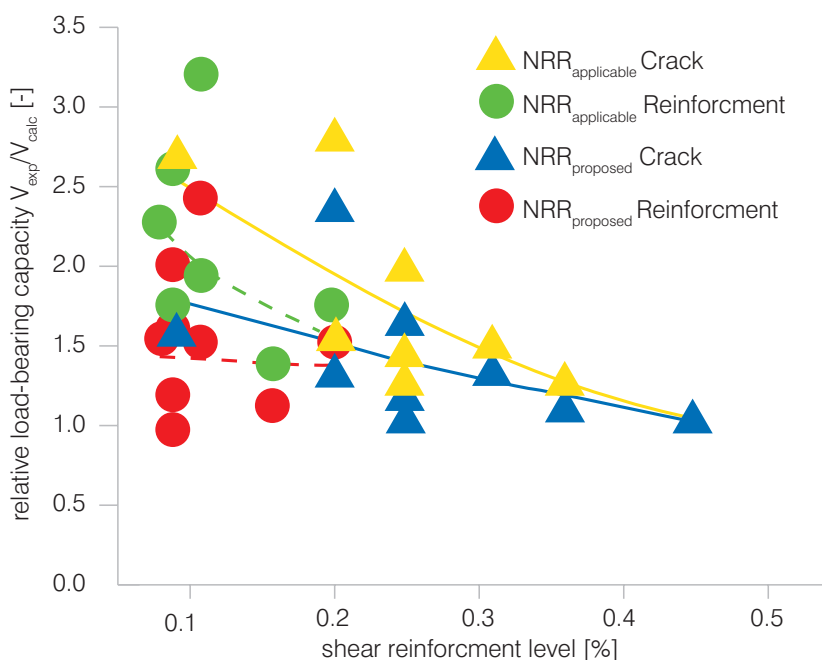

Comparison of the results of the current approach pursuant to stage 2 of the recalculation guidelines (yellow, green) with the assessment proposal (blue, red) on the basis of experimental tests (own illustration based on [1]); the round dots mark tests that were finished early to be able to conduct a second experiment using the same test beam; the triangles mark subtests during which the beam reached breaking load)

sible to answer basic questions about the appropriateness of longitudinal tendons for torsional stress and about how to take into consideration the stirrup constructions used at the time which are no longer permissible from today's point of view. Approaches for calculations were proposed to answer the two questions, which make sense from an engineering standpoint and are easy to apply.

In individual cases where it was not possible to verify an adequate safety in an ultimate limit state on the basis of the rules in the recalculation stages 1 and 2 of the recalculation guidelines, the scientific verification method (stage 4) of the recalculation guidelines needs to be applied. This type of consideration is especially appropriate for bridges that are in good general structural condition and for which

reinforcement measures can only be implemented with great difficulty. The compressive arch model (DBM) and the extended compressive arch model (EDBM) developed in previous research projects were further developed for this case study, and the application procedure was described step by step. It was also possible to present recommendations for applying non-linear finite element calculations with regard to the suitability of different safety concepts and the validation of the calculation model used.

Determining the load-bearing capacity of compression chord connections in box girder bridges

In the scope of a BASt project [2], specialists extensively studied the load-carrying behaviour of com-

pression chord connections in box girder bridges by evaluating existing tests and using numerical simulations and analytical approaches. This project showed that the load situation and load-bearing behaviour in cross sections structured in chord sections differ significantly in many aspects from the overall conditions in bar-shaped cross-sections. Direct struts, truss or compressive arch portions and therefore comparable mechanisms that contribute to the load-bearing capacity in bar-shaped cross sections cannot be transferred to the chord disks of structured cross-sections. In addition, the crack behaviour is essentially influenced by the longitudinal load situation that changes across the length of the structure. In contrast to a bar, the shear stress in a chord profile is a variable that corresponds to the longitudinal load on the chord disk.

In assessment practice, however, the assessment model developed for bar sections is used without any modifications to assess chord sections. On the one hand, this means the assessment and recalculation results are safe, but on the other in some cases they may be very conservative. This conservative assessment method makes sense in planning new bridges as it results in a robust load-bearing design, and at the same time keeps the additional costs under control when reinforcements are calculated in this way. However, more precise assessment methods are necessary for existing bridges, as reinforcements installed ex post require a lot of effort and money and are often dubious from a technical point of view.

Simple manual calculation methods were thus developed on the basis

of recalculations of experimental tests and additional calculations using simulations of structural components in dimensions that are relevant for bridge construction. These will make it possible to identify the load-bearing capacities of chords under bending compression conditions in a more realistic manner.

It was possible to show the potential of the proposed verification formats by applying them to existing older prestressed concrete bridges and comparing the results with the values identified on the basis of the current rules and regulations. At the same time, the high computational deficits (more than 200 per cent) that were calculated in recalculations based on currently applicable rules and regulations are a clear indication that the current verification formats do not determine the load-bearing capacity accurately and too conservatively.

Outlook

At the moment, proposals for a second amendment of the recalculation guidelines on short notice are being compiled to make them available for practical application prospectively in 2019. The findings of research on how to improve the verification formats for assessing shear capacity are already now significantly reducing computational deficits, thus reducing the necessary costs for reinforcements. At the same time, the large variances in the findings that are still observed in the case of poorly reinforced prestressed concrete bridges and the small test data basis for combined bending, shear and torsional stresses show there is considerable potential for future research activities. ■

References

- [1] HEGGER, J., MAURER, R., FISCHER, O., ZILCH, K., et al.: *Assessing shear and torsion capacity of existing bridges* Beurteilung der Querkraft- und Torsionstragfähigkeit von Brücken im Bestand – erweiterte Bemessungsansätze, Abschlussbericht zu BASt-Projekt FE 15.0591/2012/FRB, Bergisch Gladbach, 2018
- [2] MÜLLER, M.: *Compression chord connection in box girder bridges – Engineering model to identify load-bearing capacity* Druckgurtanschluss in Hohlkastenbrücken – Ingenieurmodelle zur wirklichkeitsnahen Ermittlung der Tragfähigkeit, Abschlussbericht BASt-Projekt F1100.2113003, Bergisch Gladbach, 2018

Expansion joints – developments in Germany and Europe

Dr. Arnold Hemmert-Halswick, civil engineer, head of the "Steel Structures, Corrosion Protection, Bridge Equipment" section



Expansion joints are the interfaces between a bridge and road structures. This is the spot where a gap forms as a consequence to exposure to different temperatures and traffic, which need to be covered by an expansion joint. For some time now, there have been German regulations in place to ensure the expansion joints fulfil the specific requirements posed to them. European regulations need to be complied with when placing expansion joints on the market in Europe.

Rules and regulations

Expansion joint made of steel and elastomers are regulated in the Additional Technical Terms of Contract and Guidelines for Civil Engineering Works (ZTV-ING), Part 8 Equipment for Engineering Structures Section 1 (ZTV-ING 8-1) and in the corresponding technical terms of delivery and technical test regulations for watertight expansion joints as steel blade constructions and finger joints with drainage at road and path bridges (TL/TP FÜ), and asphalt expansion joints in ZTV-ING 8-2 and in the corresponding technical terms of delivery for construction material to produce asphalt expansion joints (TL-BEL-FÜ) and the technical test regulations for asphalt expansion joints (TP-BEL-FÜ).

In 2013, the European Organisation for Technical Assessment (EOTA) published the European Technical Approval Guideline ETAG 032 Expansion Joints for Road Bridges for Europe. In 2019, this will probably be replaced by the technically identical European Assessment

Documents (EAD). On the basis of ETAG and EADs, applicants – usually manufacturers of expansion joints – can be certified in European Technical Assessments (ETAs). The ETAG and the EADs are the result of issuing the European Commission's Construction Products Directive and the Construction Products Regulation.

BAST coordinates the work on managing the ZTV-ING and TL/TP regulations. On the basis of ZTV-ING 8-1 and TL/TP FÜ, a compilation of expansion joints tested under technical standards, and in the near future a compilation of approvals, will be conducted on BAST expansion joints using ETA, and published on the internet.

Requirements

Requirements for expansion joints are described in technical rules to ensure they are stable, durable and suitable for use. Pursuant to ZTV-ING 8-1, this requires calcula-

tions with statistical and dynamic verifications to confirm, for instance, water impermeability. Correspondingly, the focus is on providing proof of material properties in the case of expansion joints subject to ZTV-ING 8-2.

Developments

Manufacturers have developed the joints and procedures further in many aspects to improve durability and cost efficiency. Cases in point are hybrid profiles combining structural steel and stainless steel to counteract corrosion, and using polyurethane instead of bitumen in the asphalt versions. These developments need to be represented in the technical rules to enable the proper implementation of construction measures. Additional developments will be stimulated as a result of exchanging experience at the European level. Standardisation will help to maintain an elevated quality level through transparency and competition. ■



Expansion joint in steel blade construction with noise mitigation

BASt Facts and Figures 2018

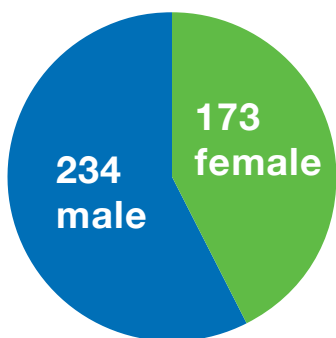

407

employees



trainees



10

visiting scientists
from abroad

700

publications and
presentations –
50 of these reports in own
publication series



quality assessments

of products from 32 groups
and 35 assessments in the
field of driving licence services



employees' average age



collaborating in

875
committees



around 300 own
research projects

74 fixed-term
contracts

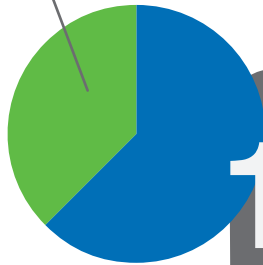

198

scientists

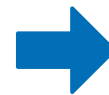
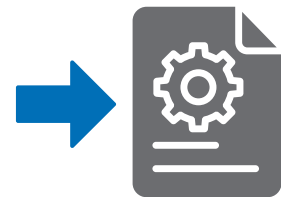

handling more than
300 external projects

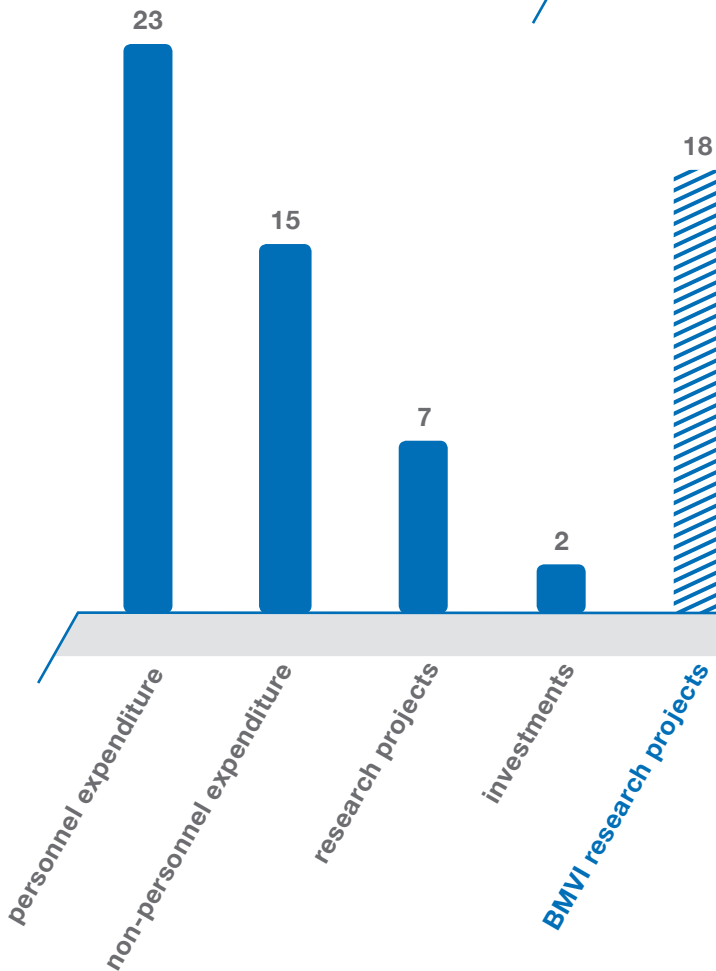

47 million
euros BAST budget



Awards/PhDs/Teaching Assignments

Various awards, appointments and PhDs and selected teaching assignments at a variety of universities and faculties also show how successful BAST employees were in 2018.



Dr. Andre Eggers received the Joseph Ströbl Award in Munich on 26 November 2018 for basic research findings on thorax injuries during passenger car crashes.



Dr. Simone Klipp has a teaching assignment at the Heinrich Heine University Düsseldorf.



Dr. Claudia Evers has a teaching assignment in traffic psychology at the German Psychologists' Academy (DPA) Berlin.



Bernhard Kollmus has a teaching assignment in "Road Safety in Planning, Constructing and Drafting Roads" at the Technical University Dresden.



Dr. Bertold Fröhlich received his PhD in natural sciences at the Johannes Gutenberg University Mainz in October 2018.



Karolina Ochwat was honoured at the Federal Ministry of Transport and Digital Infrastructure for outstanding achievements in vocational training as materials inspector with a focus on geotechnology.



Dr. Dirk Jansen has teaching assignments in highway engineering at the University Siegen.



Andre Seeck has teaching assignments at the Dresden International University (DIU) and the Technical University Graz in vehicle engineering.



Dr. Ingo Kaundinya received his PhD in engineering from the University Rostock in September 2018.



Elisabeth Shi has a teaching assignment in statistics for business psychology at the Rheinische University of Applied Science in Cologne.



Dr. Ulrike Stöckert has a teaching assignment at the Ruhr University Bochum, Faculty for Civil and Environmental Engineering, transport infrastructure chair.



Dr. Marko Wieland is a lecturer at the University Stuttgart and holds lectures at the Bavarian Bauakademie Feuchtwangen, the ABZ Mellendorf and the BFW BAu Sachsen in the scope of concrete technology training programmes.



André Wiggerich has a teaching assignment in statistics for business psychology at the Rheinische University of Applied Science in Cologne.



Prof. Dr. Ulf Zander has an honorary professorship in the civil engineering master programme at the University Siegen.

BASt Organisational Structure



